



INSTRUCTION MANUAL

www.elektrodesign.cz

DUOVENT® COMPACT RV TOP Ventilation unit with heat recuperation

SALE PRAGUE

Boleslavova 15, 140 00 Prague 4
Tel.: +420 241 00 10 10-11

CENTRAL WAREHOUSE

Boleslavská 1420, 250 01 Stará Boleslav
Tel.: +420 326 90 90 20, 30

Obsah

1. General.....	3
1.1 Introduction.....	3
1.2 Warranty.....	3
1.3 Safety regulations	4
2. General.....	4
3. Technical data.....	4
3.1 Manufacturing and information labels	4
3.2 Basic dimensions.....	7
3.3 General technical data.....	8
3.4 Operation conditions	10
3.5 Declaration of conformity	10
4. Transport, storage, acceptance.....	10
5. Installation	11
5.1 Place of installation.....	11
5.1.1 Distances from building structures (service space)	12
5.1.2 How to store the unit at the destination.....	12
5.2. Installation procedure and connection to HVAC distribution lines	12
5.2.1 Safety instructions for installation	12
5.2.2 Connection to air distribution lines	13
5.2.3 Connection of electric heater.....	14
5.2.4 Connection of water heater.....	15
5.2.5 Connection of water cooler.....	17
5.2.6 Connection of direct evaporator	18
5.2.7 Connection of condensate drain.....	18
5.2.8 Circulation (mixing) flap	20
5.2.9 Supply and exhaust flaps.....	20
5.2.10 Frequency converter of rotary heat exchanger	21
5.2.11 Basic accessories	22
5.2.11.1 Condensate drain traps.....	22
5.2.11.2 Control node for ESU water heater and ESUCH water cooler	23
6. Electrical installation	24
6.1 Connection of electric motor fans	24
6.2 Connection of electric heater.....	26
6.3 Instrumentation and control system	26
6.3.1 Digital regulation system Digireg®	26
6.3.2 Temperature regulation	26
6.3.3 Installation	27
6.3.4 Technology scheme of Digireg® I&C systems	28
6.3.5 Control.....	28
7. Commissioning.....	29
7.1 Installation and connection check.....	29
7.2 Trial operation	29
8. Operation and maintenance	29
8.1 Safety instructions for operation and maintenance.....	29
8.2 Equipment service	29
8.2.1. Filter replacement and maintenance.....	30
8.2.2. Fan maintenance	31
8.2.3. Maintenance of rotary regeneration heat exchanger	32
8.2.4. Periodic inspections	32
8.2.5. Spare parts.....	33
9. Decommissioning and recycling.....	33
Annex No. 1 – Information on Commission Regulation (EU) No. 1253/2014.....	34

1. GENERAL

1.1 INTRODUCTION

This manual is intended for ventilation units with heat recuperation DUOVENT® COMPACT RV TOP. Its purpose is to provide as much information as possible for the safe installation, commissioning and use of this equipment. Due to the fact that our products are constantly evolving, we reserve the right to change this manual without prior notice.

1.2 WARRANTY

We do not guarantee the suitability of the devices for special purposes, the determination of suitability is fully in the competence of the customer and the designer. The warranty for the devices is in accordance with valid legal regulations. The warranty is only valid if all installation and maintenance instructions, including protection, are observed. The warranty covers manufacturing defects, material defects or malfunctions of the device.

The warranty does not cover defects caused by:

- improper use and design
- improper handling (does not apply to mechanical damage)
- during transport (compensation for damage caused during transport must be claimed from the carrier)
- incorrect installation, incorrect electrical connection or protection
- incorrect operation
- unprofessional intervention in the device
- disassembling the device
- use in unsuitable conditions or in an unsuitable manner
- wear and tear caused by normal use
- third party intervention
- due to a natural disaster
- frost-damaged water exchanger parts are not covered by the warranty if it has been demonstrably proven that the unit was in operation without heating water at min. design temperature or during shutdown of the boiler circuit

When claiming the warranty, it is necessary to submit a report containing:

- data on the complaining company
- date and number of the sales document
- exact specification of the defect
- wiring diagram and fuse details
- measured values when starting the device
 - voltage
 - current
 - air temperature
 - air flow

The warranty repair is carried out in principle at the discretion of ELEKTRODESIGN ventilátory spol. s r.o. at the company's service centre or at the installation site. The method of eliminating the defect is solely at the discretion of the service company ELEKTRODESIGN ventilátory spol. s r.o. The complaining party will receive a written statement on the result of the complaint. In the event of an unjustified complaint, the complaining party pays all costs of its implementation.

Warranty conditions

The device must be installed by a professional air handling service company. **DUOVENT® COMPACT RV TOP, incl. control system DVAV, DCAV, DCOP, must be commissioned only by the Seller or by the person authorised by the Seller. Failure to comply with this condition will result in the termination of the Buyer's rights from defective performance and from the Quality Warranty. Detailed terms are specified in the Seller's Complaint Procedure.** The electrical connection must be made by a specialist electrical company. Installation and location of the device must be unconditionally performed in accordance with ČSN 33 2000-4-42 (IEC 364-4-42). The device must be subjected to an initial electrical inspection according to ČSN 33 1500. The device must be regulated to the designed air-conditioning parameters. When starting the device, it is necessary to measure the above-specified values and make a record of the measurement, confirmed by the company putting the device into operation. In the event of a complaint about the equipment, it is necessary to submit a record of the above-mentioned parameters from commissioning together with the declaration protocol together with the initial revision, which the operator acquires within the commissioning and maintenance of the electrical installation.

During the operation, it is necessary to perform regular inspections of electrical equipment within the deadlines according to ČSN 33 1500 and inspection, maintenance and cleaning of air-conditioning equipment. It is necessary to keep a „Maintenance and inspection book“ for the maintenance and service of the device, for which the device operator is responsible.

When taking over the device and unpacking it from the transport packaging, the customer is obliged to perform the following inspections. It is necessary to check the integrity of the device, as well as whether the delivered device exactly agrees with the ordered device. It is always necessary to check whether the label and identification data on the transport packaging, equipment or engine correspond to the designed and ordered parameters. Due to the continuous technical development of the equipment and changes in technical parameters reserved by the manufacturer, and the time lag between the project and the implementation of own sales, fundamental differences in the parameters of the equipment at the date of sale cannot be ruled out. The customer is obliged to inform the manufacturer or supplier about such changes before ordering the goods. Subsequent complaints cannot be taken into account.

1.3 SAFETY REGULATIONS

Adherence to these instructions should not pose any safety, health or environmental risks in accordance with EC directives (CE marked). The same applies to other products used in the device or during installation. Consider the following warnings:

- Observe the safety instructions to prevent damage to the device or personal injury.
- The technical information in this manual must not be changed.
- It is forbidden to interfere with the motor of the device.
- In order for the device to comply with EC directives, the device must be connected to the mains in accordance with the applicable regulations.
- The device must be installed in such a way that under normal operating conditions it cannot come into contact with any moving part and / or live part.
- The device complies with the applicable regulations for the operation of electrical equipment.
- Always disconnect the device from the power supply before carrying out any work on it.
- Appropriate tools must be used when handling or maintaining the device.
- The device must only be used for the purposes for which it is intended.
- This appliance is not intended for use by children under 8 years of age and persons with reduced physical, sensory or mental capabilities, or lack of experience and knowledge, unless they have been given supervision or instruction concerning use of the appliance by a responsible person. The user must ensure that children do not play with the device. Cleaning and maintenance of the appliance must not be carried out by children without supervision.

2. GENERAL

The DUOVENT® COMPACT RV TOP unit is manufactured in accordance with valid Czech and European laws, decrees, standards and technical rules. The unit may only be installed and used in accordance with this documentation. The manufacturer is not liable for damage caused by other uses and the buyer bears all risks. Changes and modifications to the complete product that could affect safety and proper function are prohibited. Installation and operating documentation must be available to the operator and service. It is advisable to place it close to the installed unit.





When disposing of the unit, the relevant environmental and waste disposal regulations must be observed. In the case of final disposal, it is necessary to follow the principles of separate collection. The applicable standards, safety regulations and generally accepted technical rules must be observed during installation, electrical connection, commissioning, repairs and maintenance of the units. Assembly of units, connection of electrical installation, commissioning of the unit, repairs, maintenance and operation may be performed only by a natural or legal person with a valid authorization.

The current version of this manual is available at www.elektrodesign.cz.

3. TECHNICAL DATA

3.1. MANUFACTURING AND INFORMATION LABELS

Each unit is provided with a manufacturing label, which contains the basic data needed to identify the device. The label is usually located on the front of the unit or on the connection side of the heat exchanger parts.

   					
TYP	Duovent Compact RV1800 T DCA DX KL F7/M5 DCOP L TOP				
VÝROBNÍ ČÍSLO		HMOTNOST	355	kg	
VYROBENO		MEDIUM PRO DX	R410A		
POPTÁVKA		MEDIUM PRO DCA	80/60	°C	
MAX. PROVOZNÍ TEPLOTA	40	°C	CELKOVÝ PŘÍKON P _{max}	1660	W
MAX. PRŮTOK VZDUCHU	1800	m ³ /h	NAPĚTÍ	Um	400 V 3N ~ 50 Hz
MAX. EXTERNÍ TLAK	620	Pa	PROUD	In	3,0 A
PARAMETRY PRO VODNÍ OHŘÍVAČ	Max.teplota 110°C : Max. tlak 1,6Mpa				

Key to distinguish the variants of DUOVENT® Compact RV TOP recuperation units („TYPE“ field on the label):

DUOVENT COMPACT RV 4 2 0 0 T D I D X M X K L G 4 + F 7 / M 5 D V A V L T O P
 1 2 3 4 5 6 7 8 9 10

- 1 – unit size – 800, 1800, 3000, 4200, 6000
- 2 – type of regeneration exchanger rotor:
 - T - temperature
 - E – enthalpy
 - S – sorption
- 3 – heater type:
 - DI – electric heater
 - DCA – water for gradient on water 80/60 °C
 - DCB – water, temperature drop on water 45/35 °C
- 4 – type of water cooler:
 - DCC – water for gradient on water 6/12 °C
 - DX – direct evaporation unit for R410A coolant, evaporation temperature 6 °C (for direct evaporation unit the coolant type, required power and arrangement of the cooling power to sections acc. to type of condensing unit used must be always specified). For evaporation units used for reverse operation with the thermal pump this fact must be specified in the order note.
 - DXr – evaporator in connection for reversible operation (cooling / heating), refrigerant R410A or R32
- 5 – MX – mixing damper with preparation for mounting the actuator
 - C – unit with mixing flap enabling 100% air circulation For the circulation mode the unit must be fitted with KL input flaps.
- 6 – KL – input and discharge flap with preparation for mounting the actuator
- 7 – filtering class of fresh air / exhaust air filter, fresh air filter with min. grade F7, exhaust air filter with min. grade M5.
- 8 – control system type
 - D – Digireg®
- 9 – air flow control type
 - VAV – variable air flow
 - CAV – constant air flow
 - COP – constant static pressure supplied to the HVAC piping network
- 10 – position of the sockets with respect to the operating side – see below (left (L) or right (P) position)

Příklady objednání

DUOVENT COMPACT RV 4200 T DI DX MX KL G4+F7/M5 DVAV L TOP

Unit size 4200 with temperature rotor of regenerator, with electric heater, direct evaporator, mixing flap, filtration on inlet G4+F7, filtration on discharge M5, I&C system Digireg® with VAV, position L (left).

DUOVENT COMPACT RV 800 E DCA F7/M5 DVAV P TOP

Unit size 800 with regenerator enthalpy rotor, with water heater 80/60 °C, with inlet filter F7, discharge filter M5, I&C system Digi-reg® with VAV, position P (right).

In addition, the unit is equipped with **labels to identify the internal arrangement of functions:**



WATER / ELECTRIC HEATER



FAN



WATER / DIRECT COOLER



FILTER

Die Einheit ist auch mit Hinweisschildern ausgestattet:



HEATING/COOLING MEDIA INPUT

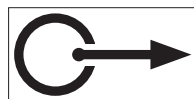

HEATING/COOLING MEDIA OUTPUT

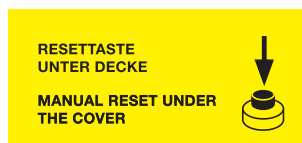

NOTICE ON LOCATION OF FAULT RESET BUTTON OF EL. HEATER

KONDENSAT ABLAUF
 CONDENSATE DRAIN



NOTICE ON LOCATION OF THE CONDENSATE DRAINAGE NECK IN THE BOTTOM OF THE UNIT

IMPORTANT WARNING

It is necessary for warranty recognition, to connect built-in thermal protection of the electric motor (see instruction manual ELEKTRODESIGN VENTILATORY).
www.elektrodesign.cz

NOTICE ON CONNECTION OF FAN MOTOR PROTECTIONS

IMPORTANT NOTICE!!

sensor located below the thermal insulation

CAUTION!
Correct function of the water exchanger anti-freeze protection requires proper insulation of the protecting (contact) temperature sensor at the water circuit return line as close to the water exchanger outlet as possible to prevent influencing of the decisive temperature by the environment temperature.

BEFORE START OF THE UNIT, THE SYSTEM MUST BE VENTED. THE VENTING SCREWS ARE LOCATED INSIDE OR OUTSIDE THE UNIT AT THE WATER EXCHANGER MANIFOLD.

WARNING OF THE NECESSITY OF INSULATION OF THE ANTIFREEZE PROTECTION CONTACT SENSOR

WARNING

Do not start and/or use the unit during constructions works (drilling, grinding etc.). There is a risk of unrepairable damage of the unit and distribution lines! The unit must be commissioned by an authorized person only!

If these instructions are violated, the manufacturer has no responsibility for any subsequent losses and the warranty for the HVAC unit becomes void!

WARNING - DO NOT OPERATE THE UNIT WHILE CONSTRUCTION WORK IN PROGRESS

Air flow measurement

$$V = K \cdot \sqrt{\Delta p}$$

Δp (Pa)
 V (m³/h)

Fan type	K (-)
RH25V, R3G250, RH25C	60
K3G250	76
RH31C	95
R3G310	116
RH35C	121
RH40C	154
RH45C	197

AIR FLOW CALCULATION PLATE LOCATED AT FAN SUCTION PRESSURE ORIFICE PORT

BEWARE!
ELECTRIC
APPLIANCE

DON'T OPEN
THE DOOR
DURING
OPERATION

WARNING LABELS

MAIN SWITCH

Labels to identify the type of air stream:

SUP
Zuluft / Supply air

ETA
Abluft / Extract air

EHA
Fortluft / Exhaust air

ODA
Außenluft / Outdoor air

3.2 BASIC DIMENSIONS OF DUOVENT® COMPACT RV TOP UNITS

Dimensional diagram of DUOVENT® Compact RV TOP without mixing flap (drawn position of the unit „L“)

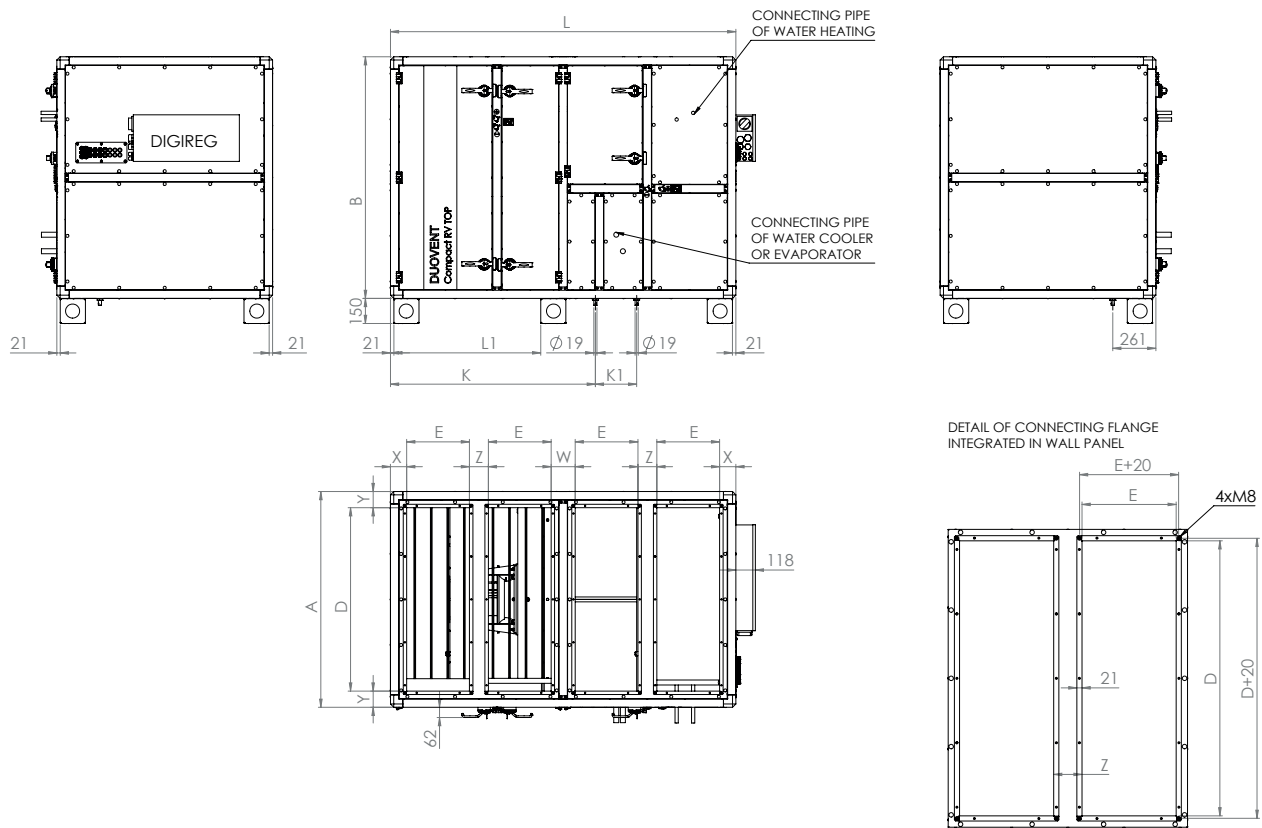

Size	A [mm]	B [mm]	D [mm]	E [mm]	F [mm]	L [mm]	L1* [mm]	K [mm]	K1 [mm]	X [mm]	Y [mm]	W [mm]	Z [mm]
800	678	914	480	190	65	1306	-	832	160	98	99	145	102
1800	992	1149	790	250	80	1620	-	1002	180	98	101	145	139
3000	1149	1306	950	300	80	1777	-	1072	230	98	100	145	117
4200	1306	1463	1110	380	80	2091	916	1240	250	98	98	145	114
6000	1463	1620	1260	420	80	2248	967	1320	250	98	101	145	113

* Sizes 800, 1800 and 3000 do not have a centre leg

DUOVENT® COMPACT RV TOP

Dimensional diagram of DUOVENT® Compact RV TOP with mixing flap (drawn position of the unit „L“)

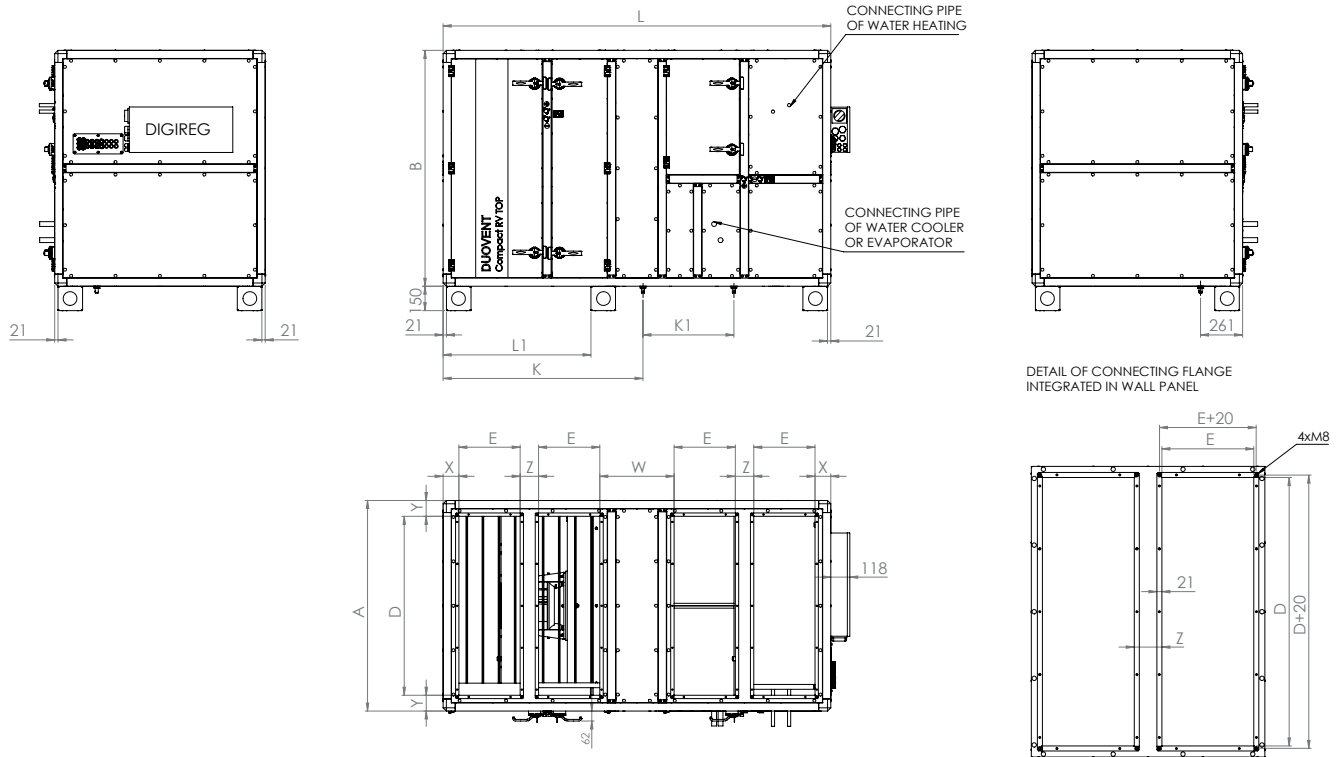

Size	A [mm]	B [mm]	D [mm]	E [mm]	F [mm]	L [mm]	L1* [mm]	K [mm]	K1 [mm]	X [mm]	Y [mm]	W [mm]	Z [mm]
800	678	914	480	190	65	1463	–	832	310	98	99	301	102
1800	992	1149	790	250	80	1777	–	1002	320	98	101	301	139
3000	1149	1306	950	300	80	2091	–	1072	530	98	100	460	117
4200	1306	1463	1110	380	80	2405	916	1240	565	98	98	460	114
6000	1463	1620	1260	420	80	2562	967	1320	620	98	101	460	113

* Sizes 800, 1800 and 3000 do not have a centre leg

3.3 GENERAL TECHNICAL DATA

Detailed technical data of the specific design of the DUOVENT® unit are part of the technical specification of the unit, which is shipped together with the unit. The technical specification is located in the packaging on the inside or outside of the service door of the unit.

The technical specifications include:

- Investor details
- Information on the installation company (or designer)
- Detailed technical data of all components of the unit (fan, recuperator, heater, cooler, filter)
- Overall dimensions of the unit and the total weight of the unit, including accessories
- Dimensional diagram of the unit, including a representation of the service space
- Specification of I&C scope, if it is part of the delivery
- Description of scope of atypical unit variant

Type	nominal airflow [m³/h]	voltage [V/Hz]	inlet/exhaust fan		heater		cooler power* [kW]	efficiency* [%]	unit max. air flow [m³/h]	control system Digireg®	weight** without MX/ with MX [kg]
			max. input power [W]	current [A]	power* [kW]	current [A]					
800	800	1x 230V 50Hz	418/372	1,8/1,6	-	-	-	78,5	800	M1-Vx	186-200 / 195-205
800 DCA					4,7	-	-				
800 DCB					3,1	-	-				
800 DCA DCC					4,7	-	5,2				
800 DCA DX					4,7	-	5,8				
800 DI					3,0	13,0	-				
1800	1800	3x 400V 50Hz	1005/736	1,6/1,2	-	-	-	77,0	2000	M3-Vx	358-370 / 371-385
1800 DCA					11,7	-	-				
1800 DCB					7,8	-	-				
1800 DCA DCC					11,7	-	15,4				
1800 DCA DX					11,7	-	13,5				
1800 DI					7,5	10,8	-				
3000	3000	3x 400V 50Hz	1422/1085	2,2/1,7	-	-	-	76,3	3500	M3-Vx	430-446 / 465-482
3000 DCA					18,2	-	-				
3000 DCB					13,3	-	-				
3000 DCA DCC					18,2	-	23,8				
3000 DCA DX					18,2	-	23,7				
3000 DI					15,0	21,7	-				
4200	4200	3x 400V 50Hz	1930/1478	3,0/2,3	-	-	-	76,6	4500	M3-Vx	545-570 / 580-610
4200 DCA					26,5	-	-				
4200 DCB					17,7	-	-				
4200 DCA DCC					26,5	-	33,4				
4200 DCA DX					26,5	-	32,7				
4200 DI					15,0	21,7	-				
6000	6000	3x 400V 50Hz	2829/2106	4,5/3,4	-	-	-	76,5	6000	M3-Vx	638-674 / 735-772
6000 DCA					36,5	-	-				
6000 DCB					26,6	-	-				
6000 DCA DCC					36,5	-	45,0				
6000 DCA DX					36,5	-	45,0				
6000 DI					22,5	32,5	-				

* at nominal air flow, $t_e = -12\text{ °C}/90\%$ rF, $t_i = 22\text{ °C}/50\%$ rF, $t_e = 35\text{ °C}/35\%$ rF (SUMMER), temperature rotor

** depending on particular variant

Water cooler power DCC for $t_e = 35\text{ °C}/35\%$ r.h., $t_w = 6/12\text{ °C}$. Water heater power DCA for $t_e = 12\text{ °C}$, $t_w = 80/60\text{ °C}$.

Water heater power DCB for $t_e = 12\text{ °C}$, $t_w = 45/35\text{ °C}$. Direct evaporating unit power DX for R410A coolant, $t_e = 35\text{ °C}/35\%$ r.h., $t_{off} = 6\text{ °C}$.

* Při jmenovitém průtoku vzduchu, $t_e = -12\text{ °C}/90\%$ r.v., $t_i = 22\text{ °C}/50\%$ r.v., $t_e = 35\text{ °C}/35\%$ r.v. (LÉTO), teplotní rotor.

** V závislosti na konkrétním provedení.

Výkon vodního chladiče DCC pro $t_e = 35\text{ °C}/35\%$ r.v., $t_w = 6/12\text{ °C}$. Výkon vodního ohřivače DCA pro $t_e = 12\text{ °C}$, $t_w = 80/60\text{ °C}$.

Výkon vodního ohřivače DCB pro $t_e = 12\text{ °C}$, $t_w = 45/35\text{ °C}$. Výkon přímého výparníku DX pro chladivo R410A, $t_e = 35\text{ °C}/35\%$ r.v., $t_{vyp} = 6\text{ °C}$.

3.4. OPERATION CONDITIONS

The unit can be used in rooms normal according to IEC 60364-5-51, resp. ČSN 332000-5-51 ed. 3, ČSN 332000-1 ed.2. The ambient temperature must be between -20 and +40 °C.

The unit can transport air without solid, fibrous, sticky, aggressive chemical and explosive additives. The maximum permissible supply air temperature must not exceed +40 °C. The maximum humidity of the air flowing through the unit is 17 g / kg s.v. (84 % r.h. at 25 °C).

If, due to the immediate climatic conditions, the humidity of the outdoor intake air reaches 100 % r.h. (wet steam), it is at the operator's discretion whether to keep the unit running with the risk of temporary separation of moisture on the internal parts of the unit (eg filters, flaps,...). This humidity cannot be the subject of a complaint.



CAUTION!

For units with a direct evaporator (marked DX and DXr in the unit code), **the design air flow through the unit must be observed** when operating the direct evaporator/condenser. It is acceptable to reduce the flow in cooling and heating mode by a maximum of 20 % of the design air flow. For proper operation of the direct evaporator, it is necessary to observe the necessary heat or cold consumption from the heat exchange surface of the evaporator/condenser. If the design amount of energy is not consumed, the condensing unit / heat pump may report a fault in the pressure protections (LP, HP) of the cooling circuit and the condensing unit / heat pump may cycle in ON/OFF mode.



CAUTION!

Units with direct evaporator (marked DX and DXr in the unit code) must be equipped with a mixing flap (marked MX in the unit code), which ensures, if necessary, min. condenser/evaporator inlet temperature of +10 °C.

3.5. DECLARATION OF CONFORMITY

This product type has been tested by the authorised person no. 227, Výzkumný ústav pozemních staveb – Certifikační společnost s.r.o., Pražská 16, 102 21 Praha 10 Hostivař, and a certificate has been issued to it. For a unit of the above type is issued a „Declaration of Conformity” within the meaning of Act No. 22/1997 Coll. as amended.

4. TRANSPORT, STORAGE, ACCEPTANCE

On the loading surface of the vehicle, the unit must be sufficiently secured against slipping and tipping over. The unit is wrapped in PE foil and placed on transport the pallet. The unit is fixed to the transport pallet by means of textile or plastic tie-ups.



CAUTION!

The holes in the frame and legs are not intended for the unit hinging.

During loading and unloading by the fork-lift the unit must be lifted suspended on the transport pallet. When transporting the unit supplied without the transport pallet it is necessary to support the unit on the underside over the entire surface to prevent damage and to pay attention to the condensate outlet opening on the underside of the unit. During lifting by a crane, it is necessary to pass the ropes through the transport pallet or under the unit to prevent their slipping. **THE UNIT CAN BE HANDLED ONLY BY SUPPORTING OR TYING UNDER THE UNIT FLOOR - THE UNIT CANNOT BE LIFTED BY THE CEILING OF THE UNIT OR OTHER PARTS (SUCH AS PNEUMATIC FLANGES, EXCHANGER OUTLETS ETC.)** Ensure proper balancing of the transported unit. The ropes above the unit must be stretched to prevent damage. Outdoor versions of the units are equipped with transport profiles for securely threading the tie-downs under the bottom of the unit.



CAUTION!

The unit shall not be transported above persons!

The units must be stored in dry and dust-free areas where the ambient temperature does not fall below + 5 °C. The unit must be protected during storage against mechanical damage, dirt and corrosion caused by permanent condensation of water vapour on the surface of the unit. During storage, it is necessary to protect the units against snow, rain and other weather conditions (store in a covered warehouse).

When accepting the unit, it is necessary to check whether the product was delivered in the agreed design and extent, whether it was not damaged during transport, whether there is no condensed water under the plastic wrap (if there is moisture under the packaging, unpack the unit and dry in a covered dry place) . In case of damage during transport, the transferee must record the extent of damage in the Delivery Note, obtain and send photo documentation to ELEKTRODESIGN ventilátory, s.r.o. Failure to comply with this procedure exposes the transferee to the risk of rejection of the complaint by ELEKTRODESIGN ventilátory, s.r.o.

5. INSTALLATION

The unit can only be installed by a professional installation company authorized in accordance with the Trade Licensing Act.

5.1 PLACE OF INSTALLATION

The unit can only be installed in accordance with the „Environmental Protocol“, in which the characteristics of all devices that can be placed in this space are clearly defined, and it is not possible to place devices that would affect these conditions in any way. The unit has a limited load capacity and is certainly not intended for storing and depositing any materials, especially objects of considerable weight. This could deform the housing of the unit or severely damage it. These damages are not covered by the warranty. After connecting the unit to the HVAC piping, it is necessary to check the insulation of the HVAC piping in parts with a risk of condensation. Condensate formed in the air duct can, in unfavourable conditions, spill into the interior of the unit, where it is not separated and may flow out of the unit. The result of this process can be damage to adjacent building structures.

Service area for servicing and repairing of units DUOVENT® COMPACT RV TOP:

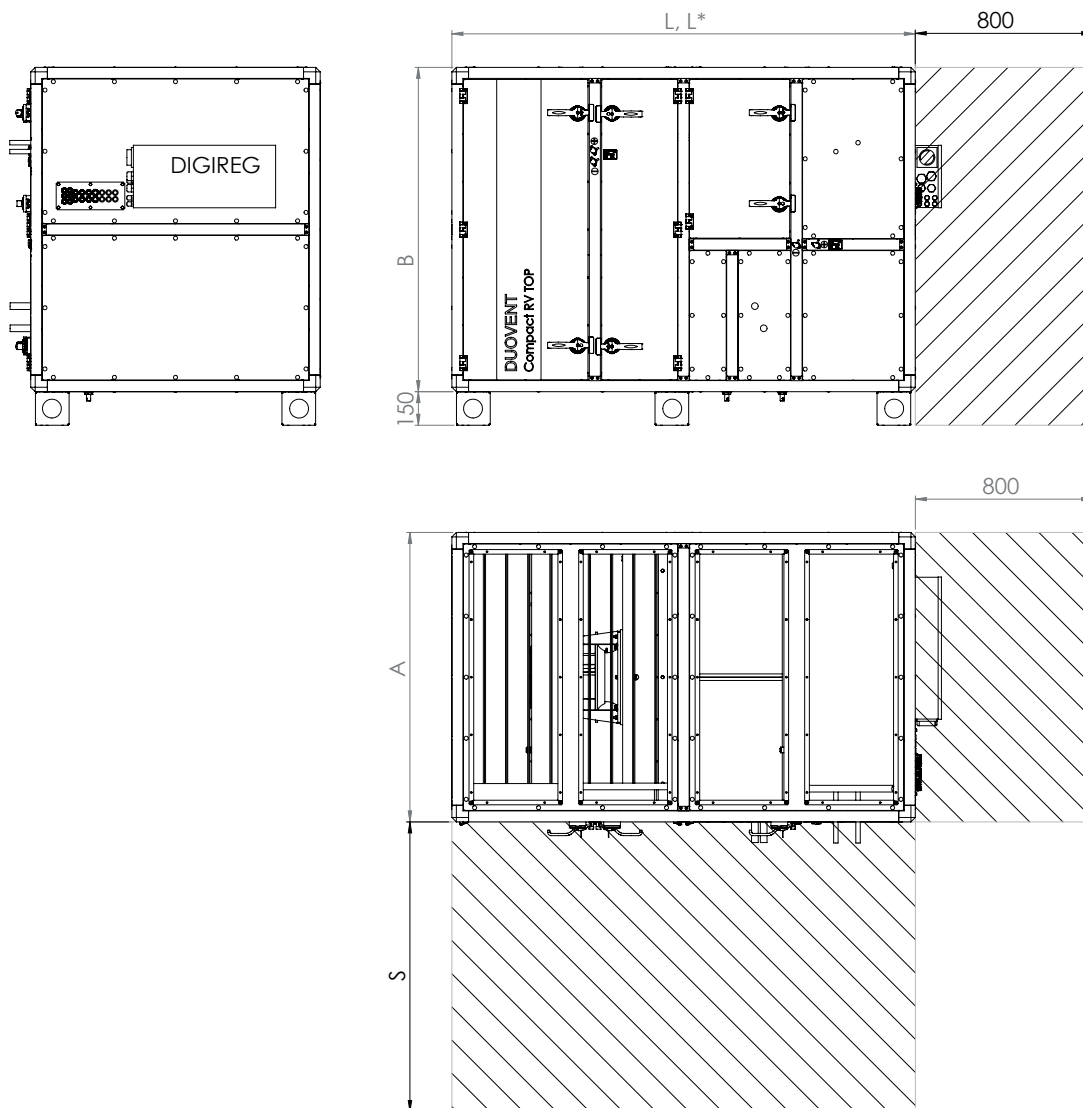

Size	A [mm]	L [mm]	L* [mm]	S [mm]
800	678	1306	1463	700
1800	992	1620	1777	1000
3000	1149	1777	2091	1200
4200	1306	2091	2405	1350
6000	1463	2248	2562	1500

L – unit length without mixing flap

L* – unit length with mixing flap

5.1.1 DISTANCES FROM BUILDING STRUCTURES (SERVICE SPACE)

Observe the minimum recommended distances from all obstacles to ensure easy maintenance and operation of the unit. If the unit is fitted with Digireg® regulation system, it is necessary to ensure free space from the system distribution box of at least 800 mm and the space for free opening of the doors. It is also necessary to ensure distances on the side of connecting the air duct to the unit. All media and I&C connections, or other constructions, must not prevent the full opening of all openings (doors) used for operation and maintenance of the unit. Unless otherwise agreed in the order, the control system distribution box will be placed in the position according to the above figures. The atypical location of the switchboard must be specified in the order. There must be free access to the distribution box; the quality of access must not be impaired by small or protruding objects in the way, slippery floors, etc. The distribution box must not be surrounded in such a way as to impair the transfer of heat to the surrounding area. It is allowed to store and store objects in the vicinity of the distribution box, a minimum space to remain free must be marked. It is not allowed to place any objects on the distribution box.

5.1.2 HOW TO STORE THE UNIT AT THE DESTINATION

The unit is designed for floor mounting in a vertical position. The unit must be placed on a solid base with a maximum limit deviation of 3 mm per 2 m of length. The unit must be supported by an anti-vibration rubber pad with a minimum hardness of 50 °Sha. The pad serves to reduce the transmission of the dynamic effects of the unit to the substrate and at the same time to reduce the noise emissions emitted by the vibrating parts of the unit. Washers are not included with the unit.

The unit must be positioned in the slope of max. 1° to the condensate drains at the operation side.

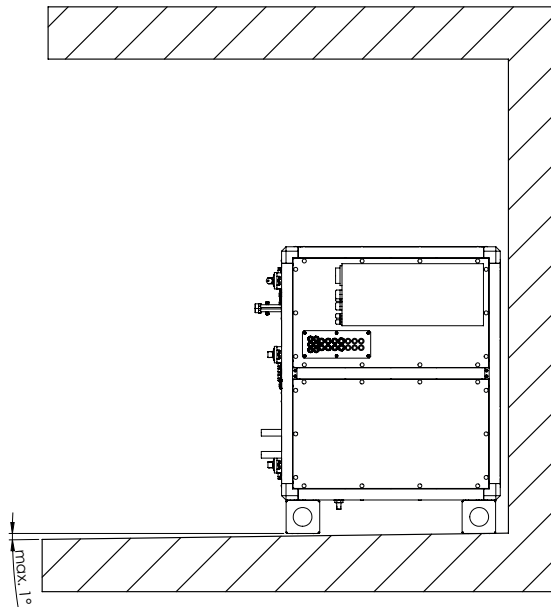

5.2 INSTALLATION PROCEDURE AND CONNECTION TO HVAC DISTRIBUTION LINES

All required dimensions and weights of the unit and accessories can be found in the „Technical data“ chapter.

5.2.1 SAFETY INSTRUCTIONS FOR INSTALLATION

Follow all safety recommendations to prevent damage to the unit or personal injury. The technical characteristics of this manual must not be changed. The motors of the unit must not be changed. The unit can be connected to a three-phase AC mains supply 400 V / 50 Hz or single-phase 230 V / 50 Hz AC networks according to the specific design of the unit. For installation in accordance with EC regulations, DUOVENT® COMPACT RV TOP units may only be connected to the mains in accordance with the applicable regulations. The device must be installed in such a way that, under normal operating conditions, it cannot come into contact with any moving or live part. DUOVENT® COMPACT RV TOP units comply with the applicable regulations for electrical equipment. Before carrying out any work on the device, **always disconnect the device from the power supply and secure the main switch of the power supply. energy against being switched on again during service work!** Always use the appropriate tools. Use the device only for its intended purpose.

5.2.2 CONNECTION TO AIR DISTRIBUTION LINES

Before connecting, check the markings and directions of the air flow in the unit. Component arrangement diagram and airflow directions:

Diagram of the arrangement of the unit components DUOVENT® COMPACT RV TOP without mixing (position left „L“)

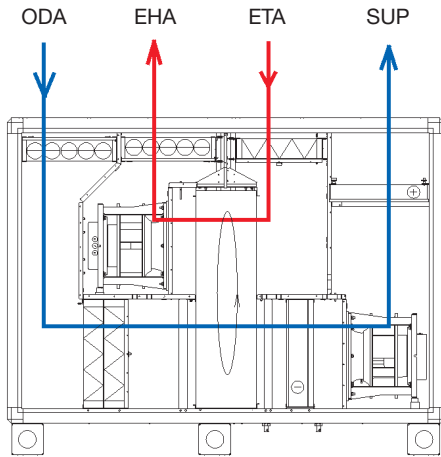
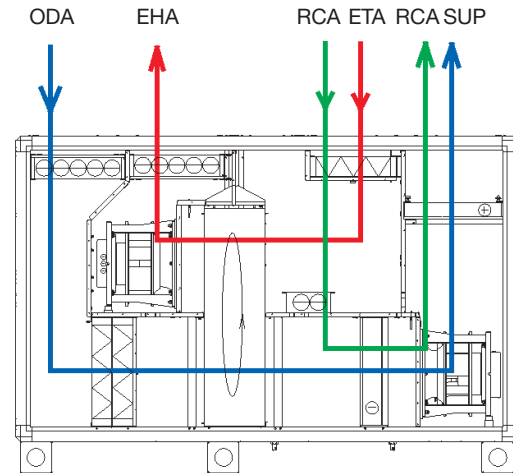

Diagram of the arrangement of the unit components DUOVENT® COMPACT RV TOP with mixing (position left „L“)



Always follow the markings and directions of airflows that are marked on the stickers on the outer casing of the unit.

The unit must be connected to the piping via flexible sleeves to prevent the transmission of vibrations to the air distribution systems. The flexible sleeves must be bridged by a flexible conductive connection for the discharge of static electricity from the device. In case the flexible sleeves are secured by distance elements against damage during transport and storage, these can be removed only after the attachment of both flanges, on the one hand to the unit and on the other to the air distribution systems.

Possible variants and positions of necks:

Neck variants - vertical design (view from the service side):

neck position left „L“

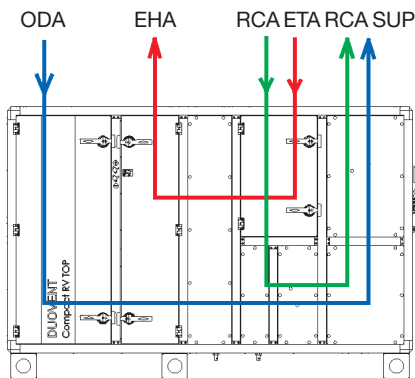

neck position right „P“

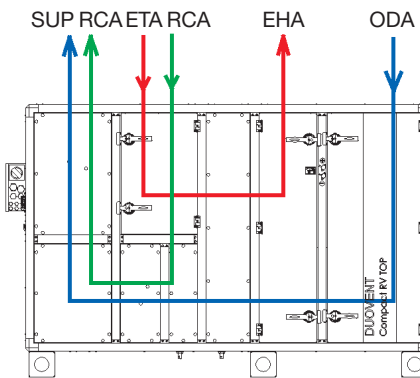

neck position left „L“

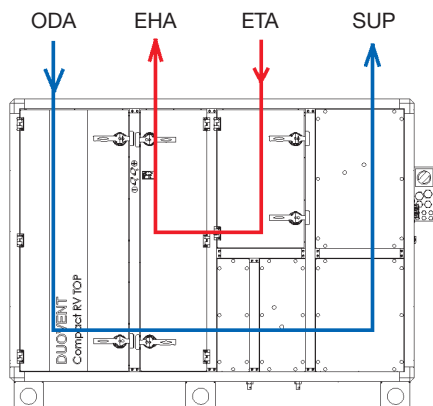

neck position right „P“

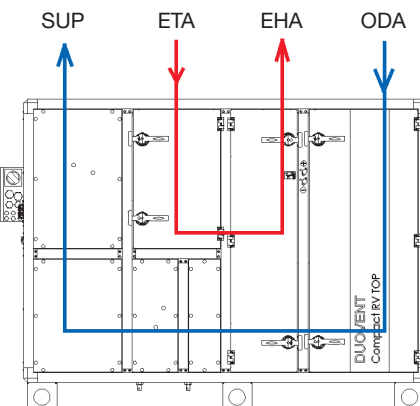

SUP – supply
ODA – suction
ETA – exhaust
EHA – waste
RCA – circulation

5.2.3 CONNECTION OF ELECTRIC HEATER (MARKED „DI“ IN UNIT CODE)

The unit equipped with an electric DI heater is connected to the relevant control system and further to the electrical network. The general safety regulations for the assembly and installation of electrical equipment apply to this equipment. On the front of the unit there is a cover with a release button for the non-automatic thermal fuse. The non-automatic thermal fuse reacts in the event of overheating of the heater's heating block (temperature above + 120°C). The electric heater is also equipped with an operating thermostat with automatic reset (set temperature is + 60 °C, when it is exceeded, the operating thermostat opens and switches off the heater, after cooling below +60°C the heater automatically switches on again).

Table of minimum air flows through the electric heater of DUOVENT® COMPACT RV TOP unita:

Size	Minimum air flow [m ³ /h]
RV TOP 800	430
RV TOP 1800	660
RV TOP 3000	1700
RV TOP 4200	2600
RV TOP 6000	3300

The release button is accessible by removing the front cover (loosen 2x M6 screws) on the outer casing of the unit.

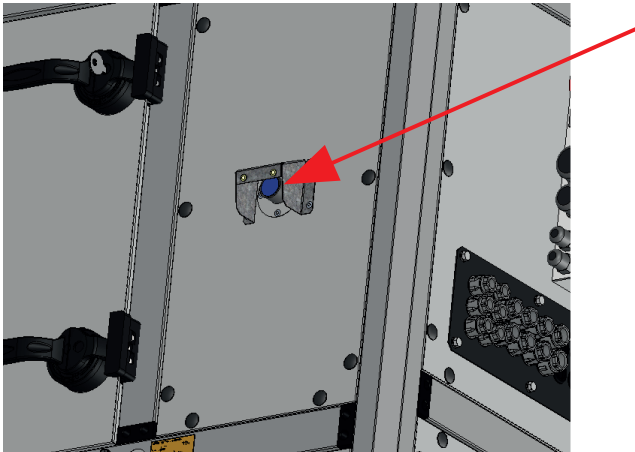

If the electric heater emergency thermostat of the unit trips again, it is necessary to immediately look for the cause of the fault. Repeated manual reset of the heater overheating error by a button on the heater is inadmissible and is not a solution to the fault. The reason for this type of failure may be insufficient air flow through the electric heater of the unit, which will cause the heating rods to overheat and the intervention of the emergency thermostat. The solution is to increase the air flow to the required minimum level according to the following table.



CAUTION!

It is forbidden to remove, bypass or disconnect safety devices, safety functions and protective devices! Any intervention in the internal connection of the heater is forbidden!



CAUTION!

before service works!

- The unit must be disconnected from the power supply
- The fan impellers shall not rotate
- Electric heater bars must be cooled to min. 30 °C
- The unit service switch is locked in OFF position

During maintenance, it is necessary to check the tightening of the terminals, clean the space of the heater terminal block from dust and dirt, monitor whether some components show signs of excessive warming, water leakage, mechanical or other damage. Increased attention must be paid to safety circuits, especially the thermal protection of the heater, including the correct response of the control system or power supply switchboard. Faults found must be rectified immediately. These inspections are carried out at least once a year (or more often according to local conditions) by an authorized professional service company.

Example of connection of the two section electric heater terminal block:

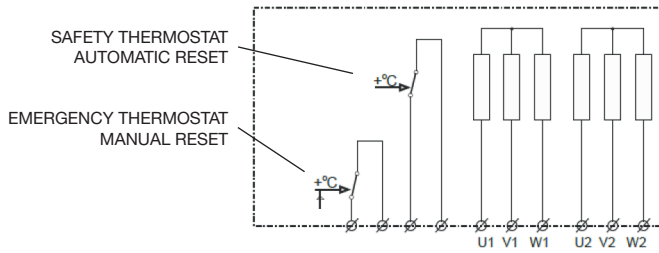

The terminal block area of the DUOVENT® COMPACT RV TOP units is accessible by removing the fixed panel with the release button cover.

5.2.4. CONNECTION OF WATER HEATER

The unit fitted with the water heater (unit code DCA or DCB) is connected to the heating media by means of three-way mixing unit (see „Types of ESU control units“). The water heater outlets are located on the front of the unit and are threaded. The exchanger must be connected in counter-current to the flow of air passing through (in concurrent connection, the exchanger loses approx. 25 % of its output). When tightening the heat exchanger connections, it is necessary, for example, to hold the heat exchanger neck with a second wrench so that the tightening torque is not transmitted to the heat exchanger body.

Table of dimensions of water cooler connection necks:

Unit size	heater type	thread
RV TOP 800	IBW-A DUOVENT® RV TOP 800 DC (80/60)	G1/2"
	IBW-B DUOVENT® RV TOP 800 DC (45/35)	G1/2"
RV TOP 1800	IBW-A DUOVENT® RV TOP 1800 DC (80/60)	G1/2"
	IBW-B DUOVENT® RV TOP 1800 DC (45/35)	G1/2"
RV TOP 3000	IBW-A DUOVENT® RV TOP 3000 DC (80/60)	G3/4"
	IBW-B DUOVENT® RV TOP 3000 DC (45/35)	G3/4"
RV TOP 4200	IBW-A DUOVENT® RV TOP 4200 DC (80/60)	G3/4"
	IBW-B DUOVENT® RV TOP 4200 DC (45/35)	G1.1/4"
RV TOP 6000	IBW-A DUOVENT® RV TOP 6000 DC (80/60)	G1.1/4"
	IBW-B DUOVENT® RV TOP 6000 DC (45/35)	G1.1/4"

For correct connection, the direction of water flow is indicated on the housing of the unit by auxiliary labels.

counter-current exchanger connection

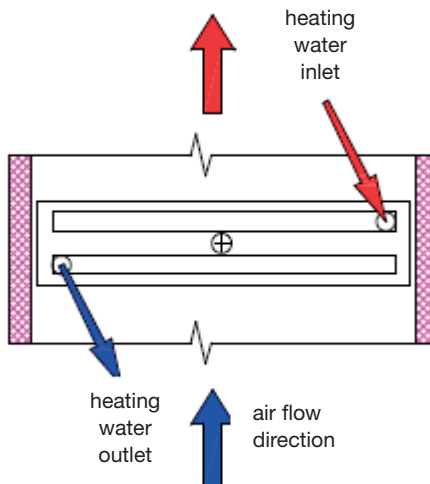

DUOVENT® COMPACT RV TOP

For the water heater to function properly, it is necessary to bleed the heater after connecting and filling the system with heating water. The vent screws are located directly at the heat exchanger connection necks. The vent screws are accessible from the outside of the service side.



Before starting service work on the heat exchanger (when replacing it), it is necessary to drain the heating water distribution system connected to the heat exchanger and drain the heat exchanger itself using the drain screws on the heat exchanger collectors. The heat exchanger can then be disconnected from the heating water distribution system and removed from the unit.

Max. operating water temperature of water heaters: **+110 °C**

Max. operating water pressure of water heaters: **1,6 MPa**

Hydrogen exponent of heating water: pH 7-9

Heating water hardness: 1,0 mval / l

If necessary, water heaters can be operated with a heating medium based on a solution of water and ethylene glycol or propylene glycol - antifreeze mixture.

For water heaters, it is necessary to pay attention to the correct installation and function of the frost protection. The frost protection sensor is located on the heating water return, or a capillary frost protection thermostat is used (depending on the unit).

All pipes must be connected independently of the heat exchangers - the heating water pipes must not act on the necks of the heat exchangers due to their weight and expansion. We recommend the antifreeze mixture as a heat transfer medium for all outdoor units.

Units taken out of service must be protected against freezing by draining water from all parts of the unit. Residual water from the exchanger can be expelled with compressed air.

When starting the unit at an outdoor air temperature below +5 °C, the active fluid supply to the heater must be opened before starting the fan, which must have the projected temperature at the heating water supply to the heater. I.e. the boiler circuit must be in operation, the boiler must heat and provide the warm water to the system.

For outdoor units, we recommend filling the water heater heating system with antifreeze mixture.

**CAUTION!**

For unit variants with water bivalence and heat pump (marked DXr DCA or DXr DCB in the unit code), it is recommended to use an antifreeze mixture of water and ethylene glycol (eg. FRITERM E Stabil) in min. concentration 1: 2 (i.e. 1 part of FRITERM E Stabil: 2 parts of water). If the antifreeze mixture cannot be used, a year-round supply of heating water must be provided in front of the water heater control valve so that all frost protection functions are active. For units that are not equipped with a Digireg control system, it is recommended to install a capillary antifreeze thermostat behind the water heater in the direction of air flow, which activates the antifreeze protection functions of the water heater in the customer control system of the unit.

5.2.5 CONNECTION OF WATER COOLER

The unit fitted with the water heater (unit code DCA or DCB) is connected to the heating media by means of three-way mixing unit (see „Types of ESU control units“). The water heater outlets are located on the front of the unit and are threaded. The exchanger must be connected in counter-current to the flow of air passing through (in concurrent connection, the exchanger loses approx. 25 % of its output). When tightening the heat exchanger connections, it is necessary, for example, to hold the heat exchanger neck with a second wrench so that the tightening torque is not transmitted to the heat exchanger body.

Table of dimensions of water cooler connection necks:

Unit size	cooler type	thread
RV TOP 800	IKW DUOVENT® RV TOP 800 DCC	G3/4"
RV TOP 1800	IKW DUOVENT® RV TOP 1800 DCC	G1"
RV TOP 3000	IKW DUOVENT® RV TOP 3000 DCC	G1.1/4"
RV TOP 4200	IKW DUOVENT® RV TOP 4200 DCC	G1.1/4"
RV TOP 6000	IKW DUOVENT® RV TOP 6000 DCC	G1.1/4"

For correct connection, the direction of water flow is indicated on the housing of the unit by auxiliary labels (the exchanger must be connected in countercurrent)

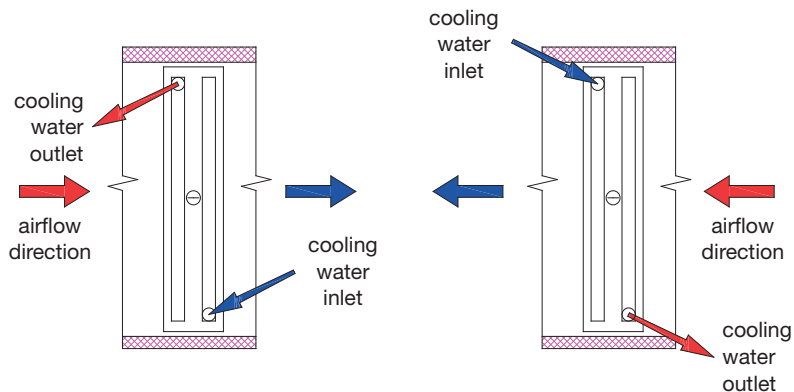

For the water cooler to function properly, the cooler must be vented after connecting and filling the system with cooling water. The vent screws are located directly at the heat exchanger connection necks. The vent screws are accessible from the outside of the service side.

Before starting service work on the heat exchanger (when replacing it), it is necessary to drain the heating water distribution system connected to the heat exchanger and drain the heat exchanger itself using the drain screws on the heat exchanger collectors. The heat exchanger can then be disconnected from the cooling water distribution system and removed from the unit.

Max. operating water pressure of water coolers: **1,6 MPa**

Hydrogen exponent of heating water: pH 7-9

Heating water hardness: 1,0 mval / l

The water cooler section is equipped with a drip eliminator, which must always be installed in the unit during cooler operation.

All piping must be installed independently of the heat exchangers - the cooling water piping must not act on the necks of the heat exchangers due to its weight and expansion. We recommend the antifreeze mixture as a heat transfer medium for all outdoor units.

Units taken out of service must be protected against freezing by draining water from all parts of the unit. Residual water from the exchanger can be expelled with compressed air.



DCA/DCB/DCC water exchanger can be used also for water with antifreeze mixture (based on propylene-glycol, ethylene-glycol etc.). We recommend e.g. concentrated antifreeze liquid FRITERM E STABIL or FRITERM P PLUS (recommended dilution for temperature resistance to -18°C 1 : 2 = 1 part FRITERM E STABIL: 2 parts of water). The recommended dilution for each type of coolant and the required frost resistance is included in the packaging of these antifreeze concentrates. For DCA / DCB / DCC water exchangers, we always recommend filling with antifreeze mixture with min. concentration of 20:80 because the liquids contain, among other things, inhibitors of corrosion. At least a minimum freezing resistance of the mixture (about -5 °C) is ensured.

5.2.6 CONNECTION OF DIRECT EVAPORATOR

The unit equipped with a direct evaporator (DX, DXr) is connected via a Cu pipe to the appropriate condensing unit or heat pump (the method and design of the connection is not the subject of these installation instructions). The direct cooler outlets are located inside or outside the unit (depending on the required design). The evaporator is filled with dry air or nitrogen from the factory. After removing the valves on the evaporator necks, work on the refrigerant circuit assembly must begin immediately. The connection of the refrigerant circuit for direct cooling must be carried out by a specialist company. It is mandatory to perform a „Refrigerant leak test“ on the refrigerant circuit. This test is performed only by a technician with the appropriate authorization (according to the law).

5.2.7 CONNECTION OF CONDENSATE DRAIN

To ensure the drainage of condensate, the outlet must be connected to the sewer system via a siphon with an odour stopper. The condensate drain neck is usually located below the rotary regeneration heat exchanger and water cooler or direct evaporator. In the case of a unit configuration without water cooler or direct evaporator, the condensate drain is blinded.

Condensate drainage for DUOVENT® COMPACT RV 800-6000 TOP and DUOVENT® COMPACT RV 800-6000 MX TOP units:

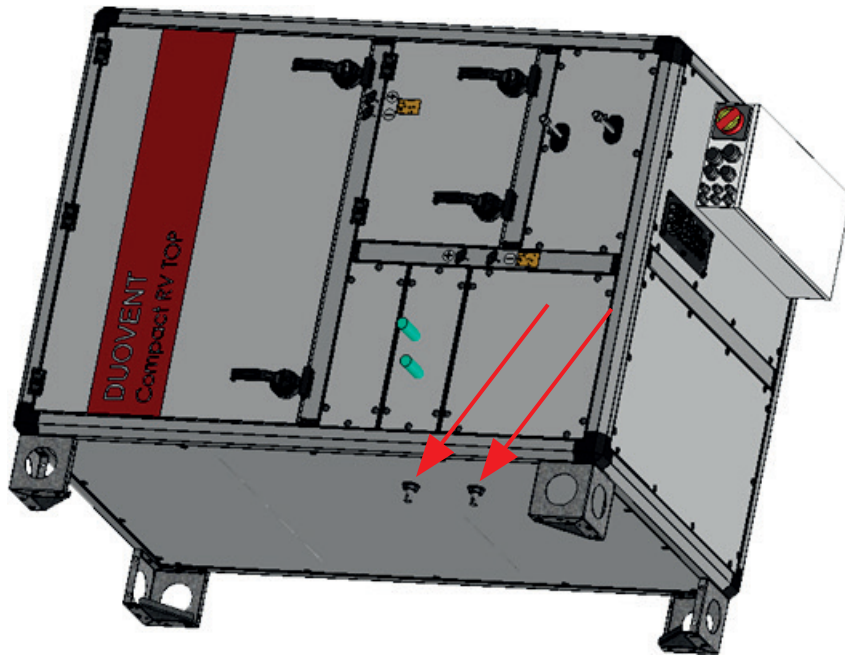

Scheme of vacuum siphon (SF-P 300):

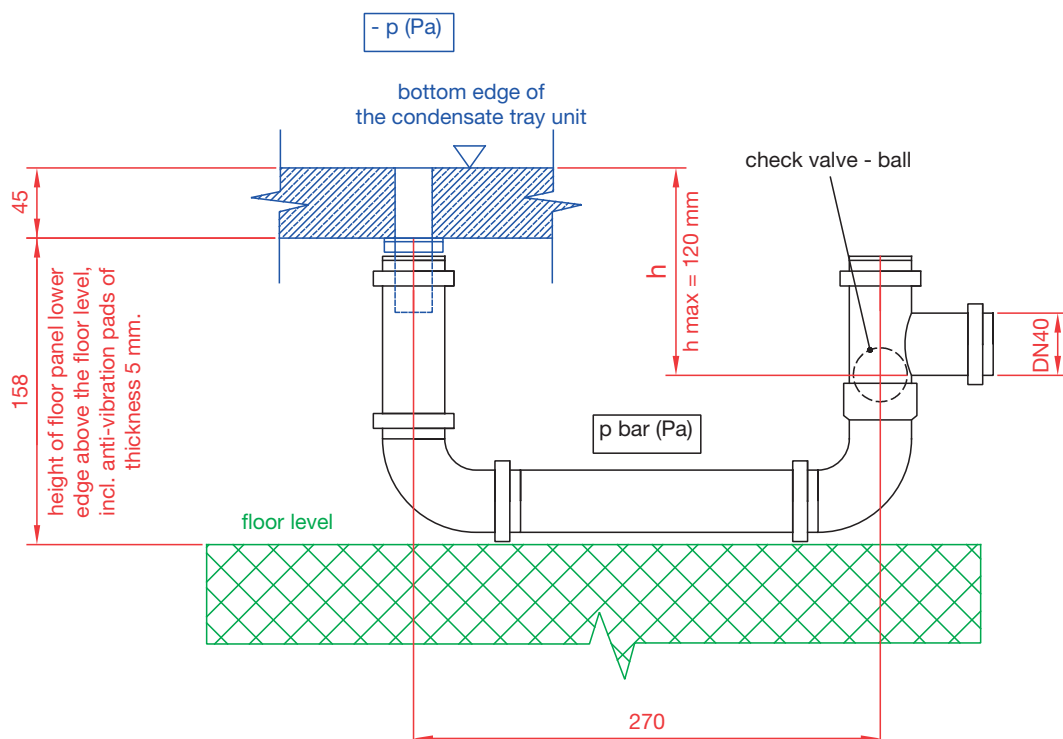

Scheme of overpressure siphon (type SF-P 400 PR):

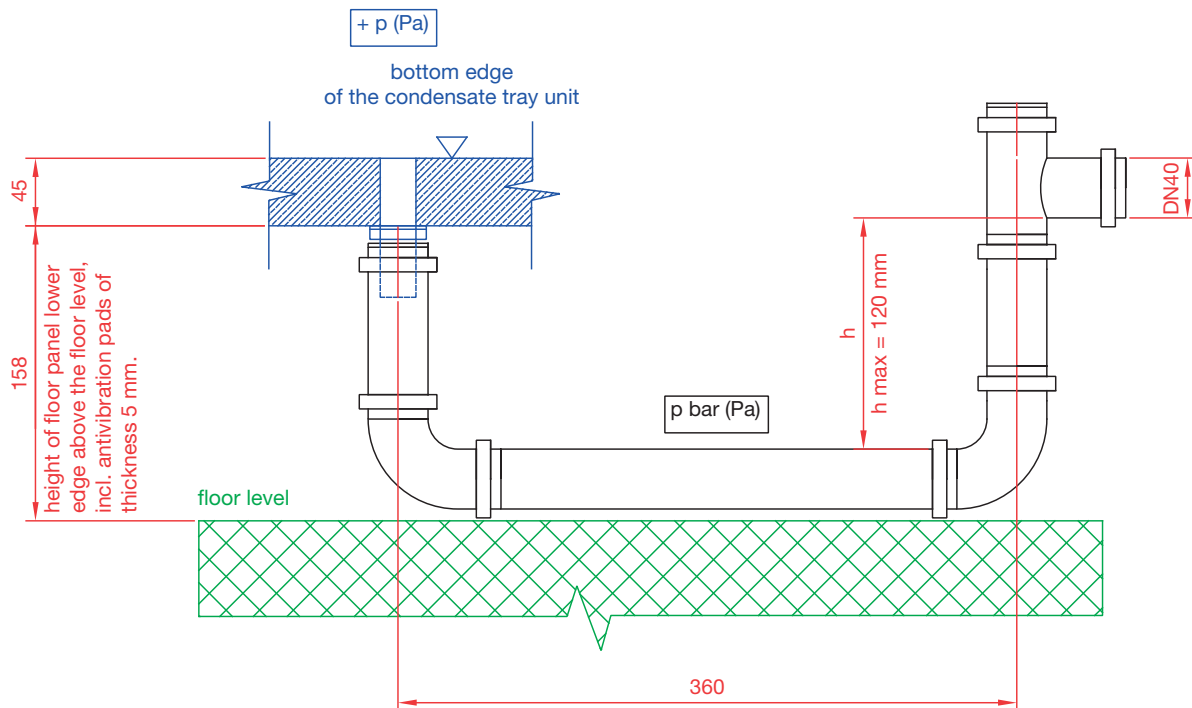

Siphon working height:

$$h = 10 + (\Delta p / 10) \dots (\text{mm})$$

Δp ... absolute value of vacuum or overpressure at a given location of the unit

On DUOVENT® COMPACT RV TOP units, the condensate drain is located under the rotary heat exchanger and under the condenser / direct evaporator in the vacuum section of the unit! This means that the absolute pressure in this condensate drain is lower than the barometric pressure outside the unit! If no siphon is connected, air is drawn in from around the unit at a very high velocity through the condensate drainage neck (opening \varnothing 16 mm) and the air drawn into the unit makes it impossible for the condensate to drain out of the unit!!!



INSUFFICIENT SIPHON WORKING HEIGHT CAUSES COLLECTION OF THE CONDENSATE IN CONDENSATE TRAY OF THE UNIT. THE CONDENSATE WILL FLOW OUT OF THE UNIT!!!

Under the air cooler (unit code DX, DXr or DCC) the siphon is located in the unit overpressure part!

Vacuum siphon (SF-P 300) - contains a ball that serves as a non-return valve for the correct function of the siphon not flooded with water and prevents the penetration of odours into the unit. The siphon must be fitted to the unit gas-tightly via the enclosed rubber sleeve. Max. usable vacuum 1100 Pa.

Overpressure siphon (SF-P 400 PR) - the siphon must be completely filled with water to prevent the penetration of odours from the sewer into the interior of the unit when it is shut down. Suitability of the overpressure siphon can be found by visual inspection. When the device is running and started, the water must not be forced into the drain pipe after the siphon has been filled. Max. usable overpressure 1100 Pa.

Siphons are used individually for each condensate drain on the unit. The condensate drain behind the individual siphons of one unit assembly can be connected to one pipe. Never connect the unit outlet necks by piping and then to single siphon. In winter, the outdoor units must be tempered by a condensate route, including anti-freeze siphons, e.g. with electric heating cables. After mounting, fix the siphon so that it does not disengage spontaneously due to the weight of the water inside.

5.2.8 CIRCULATION (MIXING) FLAP

The unit of MX variant features integrated mixing flap located in front of the rotating exchanger in direction of the exhaust air (ETA). This flap allows you to efficiently mix part of the exhaust air with fresh air or allows the circulation mode of the unit. In this mode only inlet fan is in operation. The circulation is mainly used for preheating or pre-cooling to the desired temperature. Circulation mode requires fitting the unit with additional inlet flaps (KL must be specified in the unit code).

The circulation servo (of mixing damper) is accessible by opening the unit door (ETA air side door).

Types of actuators for the circulation or mixing flaps:

Unit size	circulation flap	mixing flap
RV TOP 800	CM24-SR-L(R)	CM24-SR-L(R)
RV TOP 1800	LM24A-SR	LM24A-SR
RV TOP 3000	LM24A-SR	LM24A-SR
RV TOP 4200	LM24A-SR	LM24A-SR
RV TOP 6000	LM24A-SR	LM24A-SR

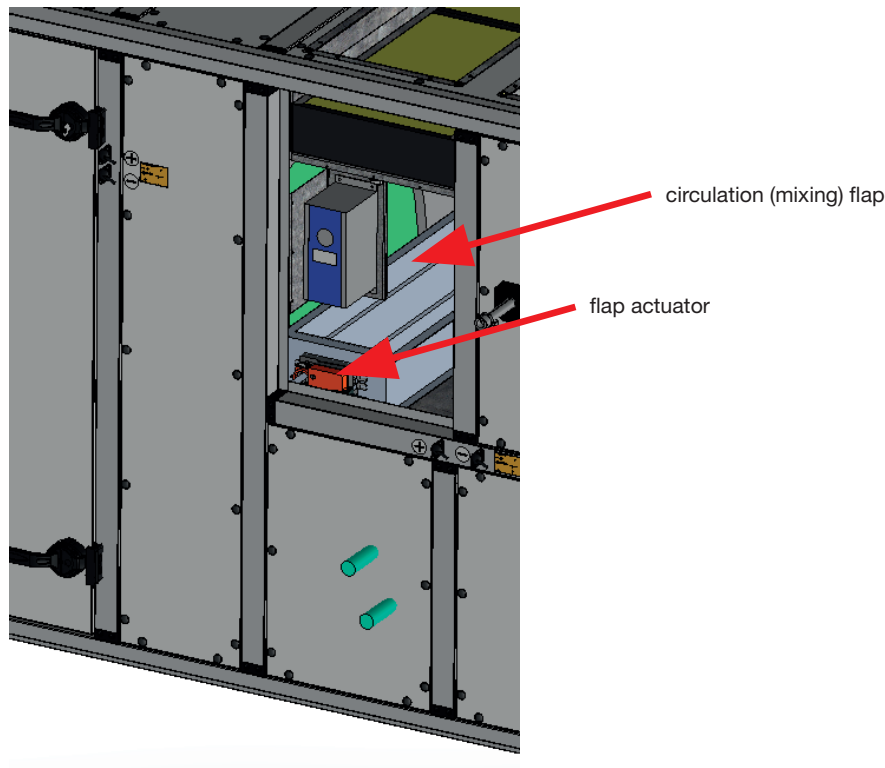

5.2.9 SUPPLY AND EXHAUST FLAPS (ODA-OUTDOOR AIR, ETA-EXTRACT AIR)

The basic version of the unit is equipped with a outdoor air and exhaust air flaps (ODA and ETA). The arrangement of the flaps in the unit is shown on the picture in chapter 5.2.2. When using a variant of the unit with a water heater DCA or DCB, it is recommended to mount an actuator with an emergency function on the fresh air inlet flap.

Unit type	ODA flap	EHA flap
RV TOP 800	TF24	CM24-R
RV TOP 1800	TF24	LM24A
RV TOP 3000	LF24	LM24A
RV TOP 4200	LF24	LM24A
RV TOP 6000	LF24	LM24A

5.2.10 FREQUENCY CONVERTER OF ROTARY HEAT EXCHANGER

The rotation exchanger is regulated by a frequency converter (e.g. type VFVN 0010-1L-0001-1), when the speed of the rotation exchanger is in the range 11–13 rpm. The frequency converter is accessible by opening the service side door in the airflow section on the ETA side.

Location of the frequency converter for DUOVENT® COMPACT RV 800-6000 TOP:

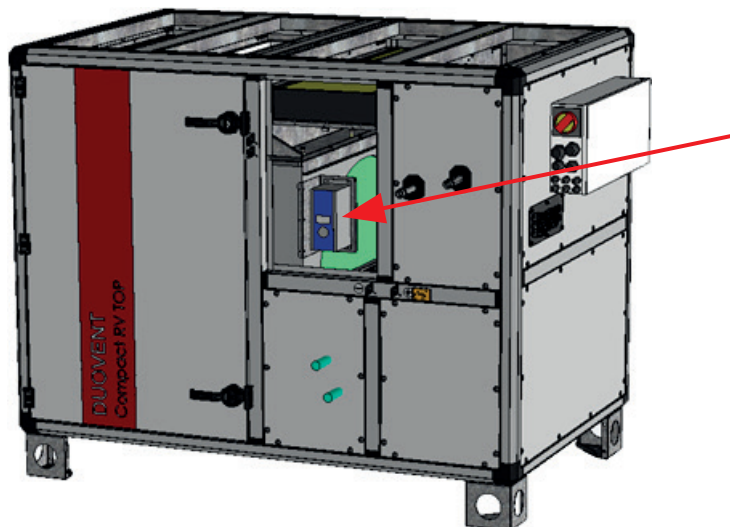

Location of the frequency converter for DUOVENT® COMPACT RV 800-6000 MX TOP:

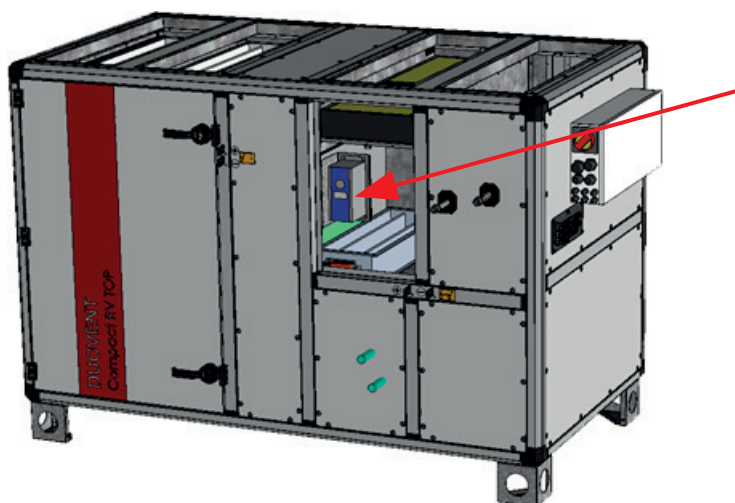

5.2.11 BASIC ACCESSORIES

5.2.11.1 CONDENSATE DRAIN TRAPS

Condensate traps must be ordered as a separate item as they are not included with the unit.

Scheme of vacuum siphon (SF-P 300):

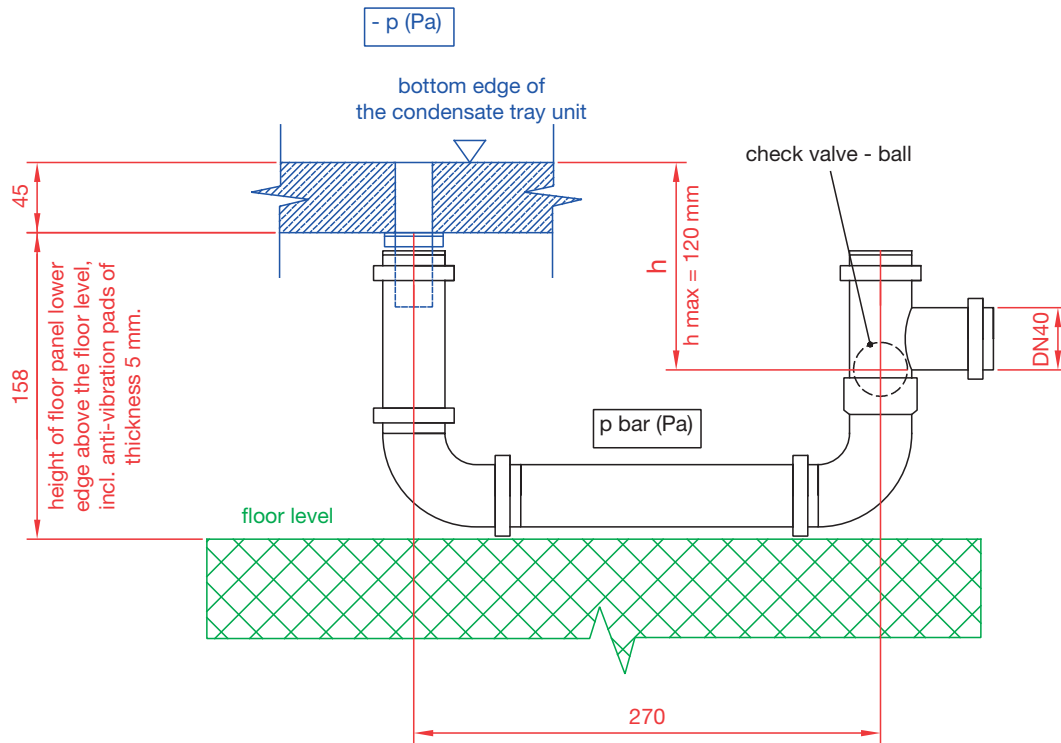

Scheme of overpressure siphon (type SF-P 400 PR):

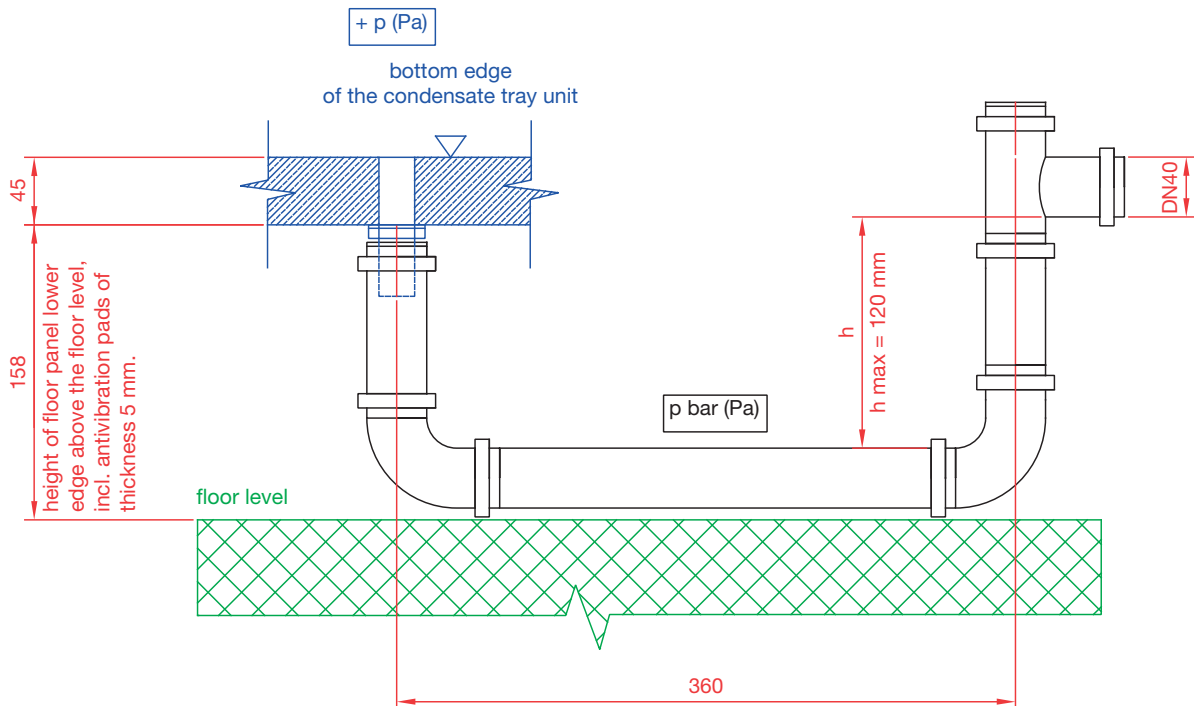

Vacuum siphon (SF-P 300) - contains a ball that serves as a non-return valve for the correct function of the siphon not flooded with water and prevents the penetration of odours into the unit. The siphon must be fitted to the unit gas-tightly via the enclosed rubber sleeve. Max. usable vacuum 1100 Pa.

Overpressure siphon (SF-P 400 PR) - the siphon must be completely filled with water to prevent the penetration of odours from the sewer into the interior of the unit when it is shut down. Suitability of the overpressure siphon can be found by visual inspection. When the device is running and started, the water must not be forced into the drain pipe after the siphon has been filled. Max. usable overpressure 1100 Pa.

5.2.11.2 CONTROL NODE FOR ESU WATER HEATER AND ESUCH WATER COOLER

The ESU or ESUCH unit must be ordered as a separate item because they are not included with the unit.



The mixing control unit is used to control the flow or temperature of heating (cooling) water to the water heaters/coolers. The ESU unit regulates the heating water temperature at the inlet to the water heater by mixing the inlet water and return line, the ESUCH unit regulates the flow of cooling water to the water cooler at a constant cooling water inlet temperature. (The designation xx in the type symbol indicates the type of GRUNDFOS pump, indicates the Kv value of the mixing valve). The control is provided by a BELIMO servomotor. For control units in conjunction with Digireg® control, it is necessary to use the design B, which features a three-point actuator, designed for control by a Digireg® controller. Version A can be controlled by a 0... 10 V signal. In addition to power regulation, the control system also provides protection of the water heater against freezing by means of the ESU unit. The water flowing through the unit may not contain impurities, solid admixtures and aggressive chemicals that damage copper, brass, stainless steel, zinc, plastics, rubber. The highest permitted operating parameters of the heating water are as follows:

- maximum water temperature +110 °C
- maximum water pressure 1 MPa
- minimum water pressure 20 kPa

The water temperature must not fall below the ambient air temperature during operation, as there is a risk of condensation in the pump motor. The minimum operating water pressure ensures that no air is sucked in by the vent valve, which must be mounted at the highest point of the water circuit. For the ESUCH unit, it is always necessary to install insulation against condensation of air humidity on the surface of the node on the entire node (suitable material is e.g. Armaflex).

Layout diagram of node components:

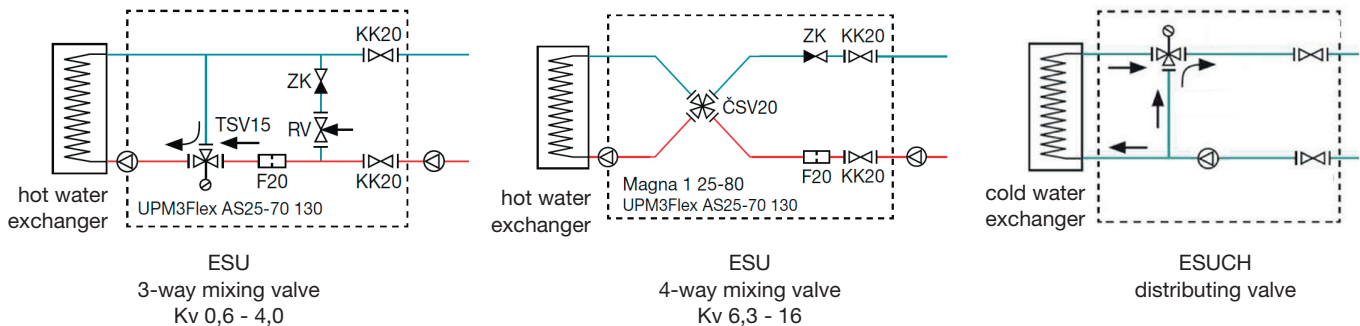

CAUTION!

The design of a suitable mixing unit must be individually adapted to the conditions of the application in order to ensure sufficient valve authority!

The mixing unit is connected to the heater or cooler. The mixing unit must never be loaded by tension and twisting of the connected piping. Mixing units should be mounted on separate hinges using heating sleeves on the wall, pipes or on an auxiliary structure. When placed under the ceiling, it is necessary to maintain control and service access to the mixing unit for easy cable connection and service access. The filter requires regular inspection, maintenance and cleaning. **When assembling the node, it is necessary to turn the filter downwards with the sludge pan. If the position is incorrect, there is a risk of increased clogging/choking of the filter. Reduced throughput or even impermeability of the filter results in a significant reduction in heater performance and increases the risk of the heater freezing.** Especially during the test operation, it is necessary to check and clean the sludge pan. If the filter is often clogged, the entire heating circuit must be cleaned. Even during normal operation of the device, it is necessary to check the filter regularly. When cleaning the filter, all water lines must be closed to minimize water leakage from the system. Always install the mixing unit so that air can escape to the heater vent points or the boiler circuit vent points. The mixing unit must be fixed so that the pump motor shaft is in a horizontal position. After flooding the system, the circulation pump must be bled according to the manufacturer's instructions (Grundfos). When connecting the mixing unit, it is necessary to check the correct setting of the valve and actuator. With an assembled mixing unit, the position of the inner segment of the mixer can be identified by the shoulder on the front of the shaft extension. The perpendicular line to the mounting surface at the three-way valve points to the axis of the inner segment. For the version with a three-way valve, proceed as follows. Of the three paths, the valve always has the path to which the bevelled surface on the valve shaft points. With an assembled mixing unit, the setting can be identified by the notch on the face of the shaft extension. The notch always points to a closed water line - see following image.

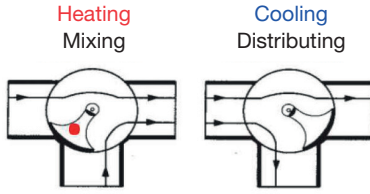

6. ELECTRICAL INSTALLATION

In general, it is necessary to observe the provisions of ČSN 12 2002 and other related regulations. The device must be disconnected from the mains during any inspection or service activities. The connection and earthing of electrical equipment must comply in particular with ČSN 33 2000-5-51 ed.3, ČSN 33 2000-5-54 ed.3 and the ČÚBP and ČBÚ decrees on professional competence in electrical engineering no. 50.

The connection of the DUOVENT® unit equipped with the Digireg® I&Ccontrol system to the electrical distribution network is made by a separate supply cable, which is not part of the delivery of the device.

6.1 CONNECTION OF ELECTRIC MOTOR FANS

Fan connection terminal block for sizes
RV 800 TOP and RV 800 MX TOP:

TERMINAL BLOCK 1.2

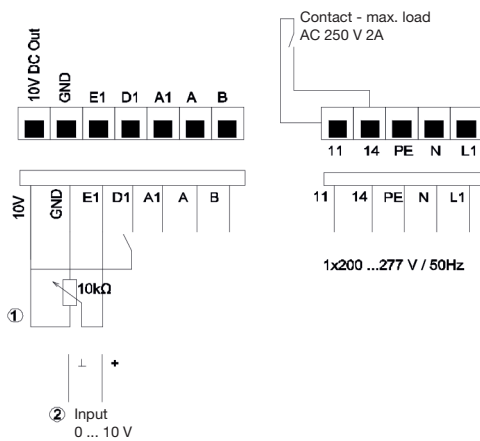

Fan connection terminal block for sizes
RV 1800 - 6000 TOP, RV 1800 - 6000 MX TOP

TERMINAL BLOCK 1.3

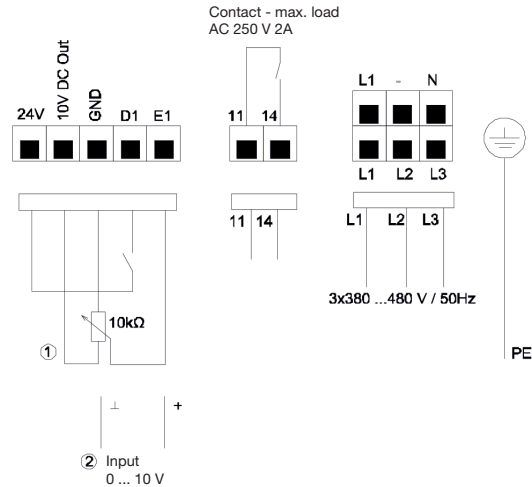

Legend for connection of terminal blocks:

①- Entered speed, e.g. of external potentiometer REB-Ecowatt. Connected to terminals „+10 V“ and „GND“ with sensor at terminal „E1“.

②- Excitation via external signal 0... 10 V.

L1, N, PE – network connection for types 1~

L1, L2, L3, PE – mains connection for types 3~

11,14 – relay output for fault reporting. During operation, terminals „11“ and „14“ are bridged (relay is closed). In the event of a fault, the relay opens. When switched off with D1 (digital input set to 1), the relay remains closed.

E1, GND – analog input for entering the speed 0... 10 V

10 V DC Out – voltage supply for entering the speed using an external potentiometer REB Ecowatt

D1,+24 V (resp.+10 V) – digital input. Fan on = contact closed. Fan off = contact open.

A1 – status/tacho open-collector output (Imax = 20 mA)

A,B – Modbus (RS-485) interface

Fan connection terminal block for sizes RV 800 TOP, RV 800 MX TOP (with fan type R3G):

TERMINAL BLOCK 1.4

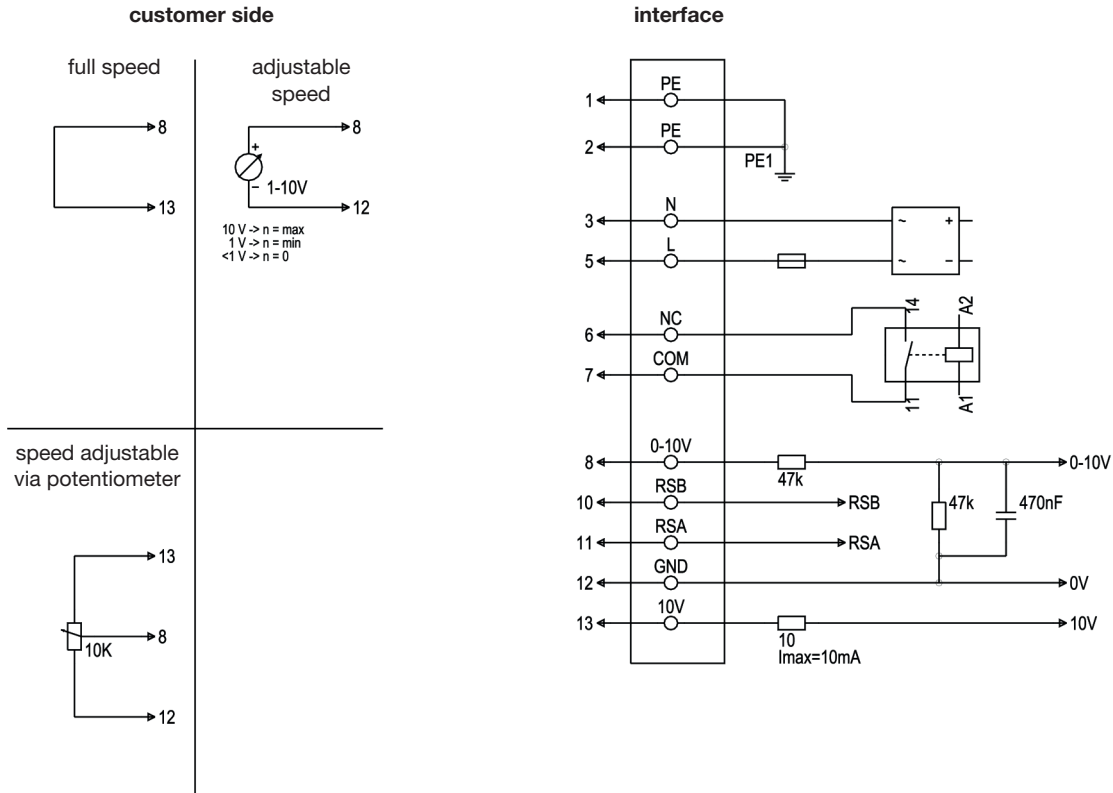

No.	fol.	marking	colour	function / assingment
1	1, 2	PE	green / yellow	protective conductor
1	3	N	blue	supply voltage, neutral conductor, 50/60 Hz
1	5	L	black	supply voltage, phase, 50/60 Hz
1	6	NC	white 1	status relay, potential-free contact of status message; contact opened with fault, contact rating 250 V AC / 2 A (AC1) min. min. 10 mA, basic insulation against the mains and reinforced insulation against the control interface
1	7	COM	white 2	status relay, potential-free contact of status message, common connection, contact rating 250 V AC / 2 A (AC1) / min. min. 10 mA, basic insulation against the mains and reinforced insulation against the control interface
2	8	0 - 10 V	yellow	analogue input (setpoint) 0-10 V, Ri = 100 kΩ; parametrizable characteristic
2	10	RSB	brown	RS485 interface for MODBUS, RSB
2	11	RSA	white	RS485 interface for MODBUS, RSA
2	12	GND	blue	reference ground for control interface, SELV
2	13	+10 V	red	fixed voltage output 10 V DC; +10 V ±3 %, max. 10 mA; permanently resistant to shortage, power voltage for ext. equipment (e.g. potentiometer)

6.2 CONNECTION OF ELECTRIC HEATER

The cables of the electric heater are led to the terminal board of the electric heater and properly marked for the subsequent connection of the control and management system.

Type connection of the electric heater terminal block for DUOVENT® units:

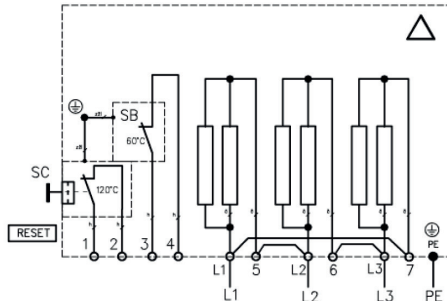

SC ... emergency thermostat with manual reset
SB ... operating thermostat with automatic reset



POZOR!

SB and SC safety devices must always be connected to the contactor circuit of the electric heater!

6.3 INSTRUMENTATION AND CONTROL (I&C) SYSTEM

The standard part of the unit is its own control system. The design of the unit is ready for cooperation with the Digireg® digital controller.

6.3.1 DIGITAL REGULATION SYSTEM DIGIREG®

The control system is located in a compact sheet steel switchboard equipped with a main switch, digital controller on the PCB board and safety and switching elements for individual HVAC units. The cables pass through plastic bushings with locking in the left side of the cabinet.

Basic dimensions of Digireg® M3-Vx switchboard with protection level IP20:

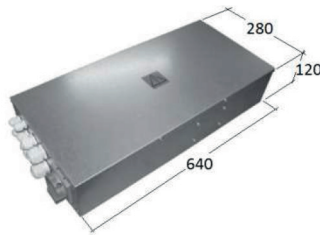

The switchboards M1-E2 to M3-E36 have dimensions 660 x 660 x 120 mm.

The Digireg® switchboard with IP65 protection has dimensions of 640 x 600 x 210 mm.

6.3.2 TEMPERATURE REGULATION

The Digireg® controller is designed to control the output of the heater or cooler of the air handling unit to reach the desired temperature. The Digireg® can command direct cooling or a heat pump. There is a 3-point output for servo drive of the mixing valve, direct power outputs SSR for electric heating or two analogue outputs 0–10 V / 0–20 mA. The heat pump or cooling unit is controlled by potential-free contacts.

- Regulation to a constant supply air temperature**
 uses one temperature sensor in the supply pipe, the supply air is heated or cooled to the required set temperature within the minimum and maximum configured temperature
- Regulation to a constant temperature of the exhaust air**
 uses one temperature sensor in the exhaust pipe, the supplied air is heated or cooled to the required set temperature within the minimum and maximum configured temperature
- Spatial temperature control (for constant room temperature)**
 Cascade control is used with limitation of the minimum and maximum supply air temperature. The main sensor is placed in a ventilated area, the supply air sensor is placed in the outlet of the unit in a place with sufficient air mixing. If the room temperature is higher than the set value, the controller will try to reduce the supply air temperature to the set minimum supply air temperature. If the room temperature falls below the set value, the controller tries to compensate for this by increasing the supply air temperature. The room temperature can be selected as the room temperature, the temperature from the sensor in the controller, or from a separate sensor connected to the motherboard. The controller cools or heats according to the set parameters in the automatic summer/winter mode according to the outdoor temperature and time dependencies. Manual mode selection is also possible. The heater can be hot water, controlled by a three-point actuator, or electric, directly controlled by SSR, or external TRIAC switches 0-10 V. Electric heater controlled by internal SSR can have up to 36 kW depending on the cabinet, water heater is not limited mixing unit size). Cooling can be cold water, controlled by a 0-10 V analog actuator or direct in conjunction with a condensing cooling unit.

**CAUTION!**

For units with a direct evaporator (marked DX and DXr in the unit code), it is possible to maintain the required air temperature in the room with accuracy, depending on the correctness of the project and the correct function and setting of the ventilation system with accuracy of $\pm 2^{\circ}\text{C}$.

6.3.3 INSTALLATION

Controllers with IP20 protection are designed for installation in an indoor dry environment without aggressive chemicals in normal areas according to ČSN 33 2000-3, ambient temperature up to 30 °C.

The short-circuit resistance of the Digireg® switchboard is 6 kA. Distribution board protection is IP20 or IP65 and the material is listed below in the catalog sheets at www.elektrodesign.cz.



For heat recovery units supplied with a free located Digireg® control box, which is not fixed to the unit wall, the firm housing must be ensured of harness between the unit and control box in the firm cable line (such as cable trays, cable bench etc.). The harness between the unit and the control box shall not be freely suspended or positioned on the floor!!! After firm laying of the harness it is possible to start the works on connection of individual wires to the Digireg® control box.

**CAUTION!**

Digireg® distribution boards are not designed for direct installation to the flammable material!

Cross-sections of power cables (fans, pumps, electric heaters...) must be designed according to specific installation conditions in accordance with ČSN 33 2000-5-52 ed.2.

The installation must be carried out by an authorized person working on electrical equipment in accordance with legal requirements and familiar with the function of the individual components of air conditioning and control. Observe the valid ČSN during installation. **An initial inspection must be performed before commissioning.** For the assembly and installation of air conditioning, an authorized project of air conditioning and M&R is required, which solves both the air outputs and the piping system, as well as the electrical connection of elements and operating modes.

The actual commissioning and setting of the basic parameters of the controller must be performed by an authorized company with authorization and training from ELEKTRODESIGN ventilátory, s.r.o.

The cables must be secured outside the unit against being pulled out in the installed bushings.

The cable routes of safe and mains voltage must be separated due to electromagnetic compatibility requirements. It is necessary to build 2 cable routes at a distance of at least 20–30 cm from each other, if possible with a minimum of crossing. A grounded metal partition in the entire height of the metal grounded gutter is also permissible.

If the main supply has a conductor cross-section of less than 6 mm², we recommend connecting the controller to the earthing system with a copper conductor with a cross-section of at least 6 mm² due to the impedance of the earth conductor for high-frequency interference. We recommend to fit the power supply with surge protectors.

It is necessary to check the function of all connected elements, especially emergency inputs, the direction of rotation of the fans, the correct phasing of the damper actuators and mixing valves. If the unit is equipped with Digireg® control system directly from the factory, a SETPACK test package has been performed on the unit. SETPACK covers basic settings of control system parameters and testing of all peripherals.

6.3.4 TECHNOLOGY SCHEME OF DIGIREG® I&C SYSTEMS

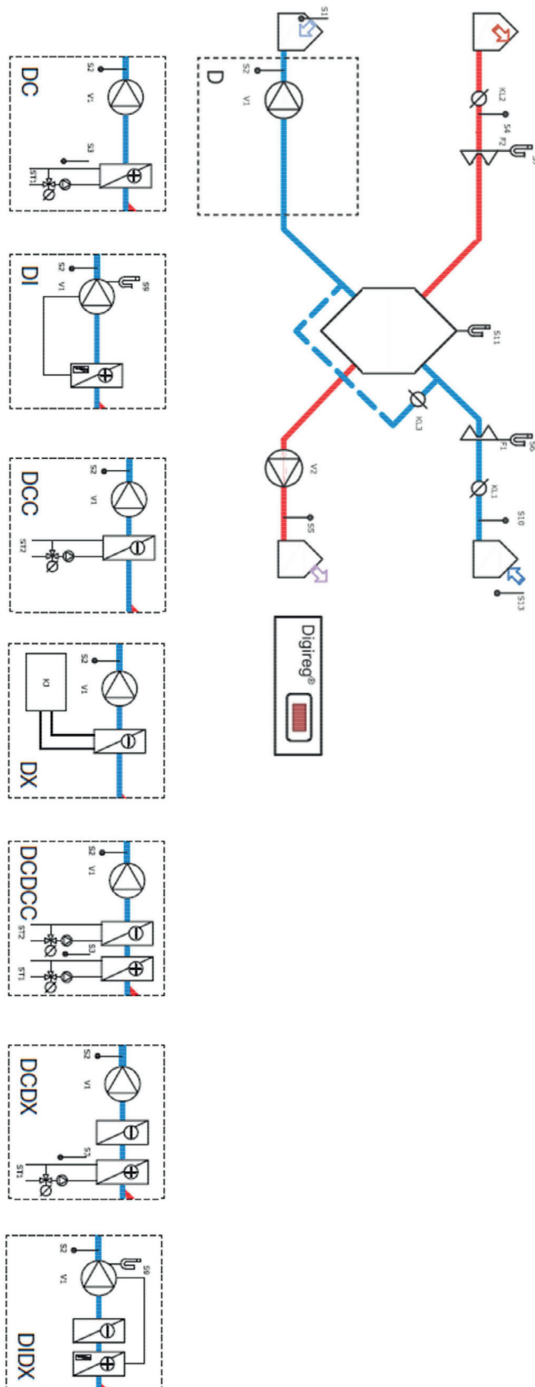

Legend to schemes

- S1 room temperature sensor
- S2 supply air temperature sensor
- S3 temperature sensor for frost protection of water heating
- S4 temperature sensor for exhaust air
- S5 exhaust air temperature sensor
- S6 pressure sensor on the supply filter
- S7 drain filter pressure sensor (optional)
- S8 thermostat as protection against freezing of the direct evaporator
- S9 supply fan pressure sensor (mandatory - monitors fan operation)
- S10 intake air temperature sensor
- S11 recuperator icing sensor
- S13 outdoor temperature sensor (enable condenser unit operation)
- V1 supply fan
- V2 exhaust fan
- KL1 inlet flap actuator (circulation)
- KL2 outlet flap actuator (can be coupled with KL1)
- KL3 recuperator bypass actuator
- KL4 mixing actuator for integrated flaps
- ST1 heating water mixing valve actuator
- ST2 cooling water mixing valve actuator
- KJ condensing unit

6.3.5 CONTROL

The controller is operated exclusively via the touch control. Service settings are performed by the appropriate service program, which is only available to trained and certified companies.

Touch control CP for Digireg®:

Operating instructions for Digireg®:



Detailed settings and control of the controller are in the manuals for individual control systems. The instructions are available at www.elektrodesign.cz.

7. COMMISSIONING

The device may only be put into operation for the first time by a suitably qualified specialist.

7.1 INSTALLATION AND CONNECTION CHECK

Before the first commissioning, it is necessary to check:

- Equipment cleanness, installation completeness/quality
- Fan free rotation
- Operating voltage of installed control system
- Operating voltage of electric motor acc. to type plate
- Actuator control and operating voltage
- Function of condensate drain and trap water flooding
- Cleanness of filter cartridges
- Flap movability
- Tight connection to distribution lines
- Closing of all doors and service holes

Any faults must be rectified before starting the unit for the first time.

7.2 TRIAL OPERATION

The material content of the comprehensive testing includes the commissioning of the device for a pre-agreed time and its continuous inspection. In order to comply with the required air parameters depending on the operation of the building and the technology, it is necessary to fine-tune the device during the test operation, or during the warranty tests.

For the first start of the air handling unit, the company ELEKTRODESIGN ventilátory, s.r.o. offers the **STARTPACK** assistance service package. Find out about the conditions and scope of the **STARTPACK** package at www.elektrodesign.cz.

The company putting the unit into operation is obliged to demonstrably train the user's staff. Without proof of operator training, the warranty will not take effect and the device must not be operated.

8. OPERATION AND MAINTENANCE

These instructions serve as an aid for professionals, operators of air handling units, or investors who are assumed to already have experience with the operation of air conditioning systems. The instructions are especially important for the start-up period of the entire system, when more detailed operating regulations are not available. The purpose of these instructions is to allow temporary operation of air handling units and to prevent possible operator errors. Final operating regulations must be prepared in accordance with the operating regulations of the entire building.

8.1 SAFETY INSTRUCTIONS FOR OPERATION AND MAINTENANCE

Follow all safety recommendations to prevent damage to fans or personal injury. The technical characteristics of this manual must not be altered. The unit motors must not be changed. The unit may be connected to a three-phase AC mains supply. 400 V / 50 Hz or 230 V / 50 Hz single-phase mains for sizes RV 800 TOP, RV 800 MX TOP. For installation in compliance with EC regulations, the units must only be connected to the mains in compliance with the applicable regulations. The unit must be installed in such a way that under normal operating conditions it cannot come into contact with any moving or live parts. DUOVENT® COMPACT RV TOP units comply with the applicable regulations for electrical equipment. **Always disconnect the unit from the power supply first before carrying out any work on the device.** Always use appropriate tools. Only use the device for its intended purpose.

8.2 EQUIPMENT SERVICE

To maintain the efficiency of DUOVENT® COMPACT RV TOP units, regular maintenance is required.



CAUTION!

- The unit must be disconnected from the power supply
The unit service switch is locked in OFF position.
- The fan impellers shall not rotate!
- Electric heater bars must be cooled to min. 30°C!

8.2.1 FILTER REPLACEMENT AND MAINTENANCE

The filter replacement interval can vary considerably depending on the operating conditions and where the unit is located (the level of outdoor pollution depends on the location near industrial areas, roads or highways, forests or agricultural areas). The filter change interval ranges generally from 6 to 12 months. After unlocking the locks, open the relevant door of the unit. Pull together to remove and then replace all filters on the unit.

Plate filter dimensions:

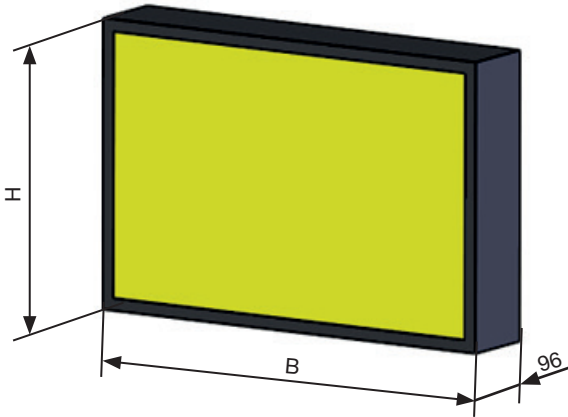
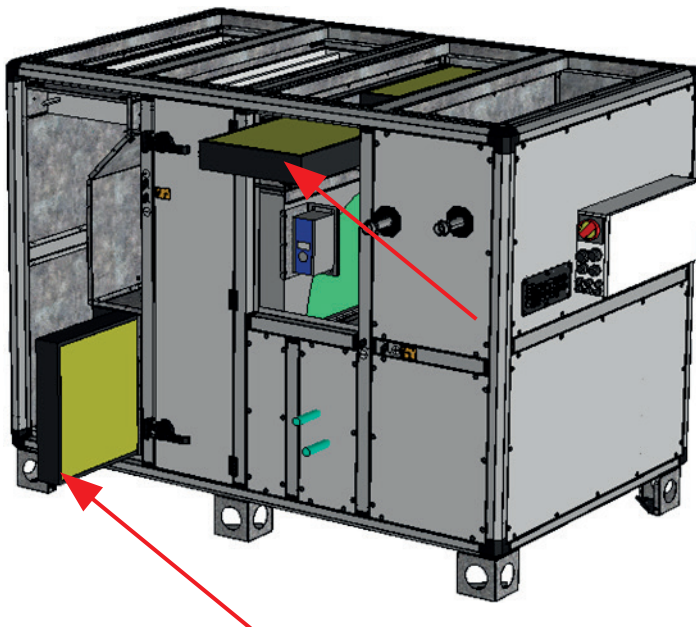

Table of filter cartridge dimensions for RV 800-6000 TOP (filter cartridge dimensions are the same for MX, C units)

Unit size	unit position	filter class	frontal dimension BxH		cartridge width [mm]	number of pieces
			B [mm]	H [mm]		
RV TOP 800	left (L), right (P)	F7	578	260	96	1
		M5	578	245	96	1
RV TOP 1800		G4	446	360	96	2
		F7	446	360	96	2
RV TOP 3000		M5	446	340	96	2
		G4	525	450	96	2
		F7	525	450	96	2
RV TOP 4200		M5	525	350	96	2
		G4	603	520	96	2
		F7	603	520	96	2
RV TOP 6000	M5	603	410	96	2	
	G4	682	600	96	2	
	F7	682	600	96	2	
		M5	682	440	96	2

Procedure for changing the filters - slide the filters out of rails after opening the door:



8.2.2 FAN MAINTENANCE

The fans are protected by filters and therefore only light contamination can occur. Nevertheless, a visual inspection every 5 years is recommended. Remove dust from the impeller with a dry (not wire!) brush or by blowing with compressed air. Check the condition of the electric motor bearings. The supply fan can be dismantled in two ways. Remove the lower side panel or the lower panel on the service side. To remove the panels, the plastic tube covers must be removed. The panels are screwed in place with self-drilling square head screws. To remove the exhaust fan, open the door panel of the unit. For sizes RV 4200-6000 TOP, open the two doors and remove the center divider. The fans are mounted on rubber silentblocks. Loosen the 4 nuts, lift and remove the fan as shown in the following illustrations. Keep in mind that the fan must be dynamically and statically balanced again after removing the electric motor.

Removal of the supply fan for DUOVENT® COMPACT RV 800-6000 TOP - removal of the lower side panel:

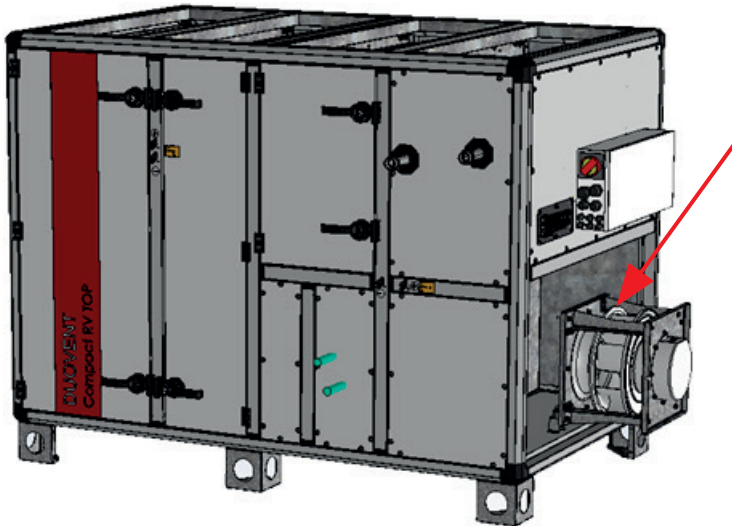

Removal of the supply fan for DUOVENT® COMPACT RV 800-6000 TOP - removal of the bottom panel of the service side:

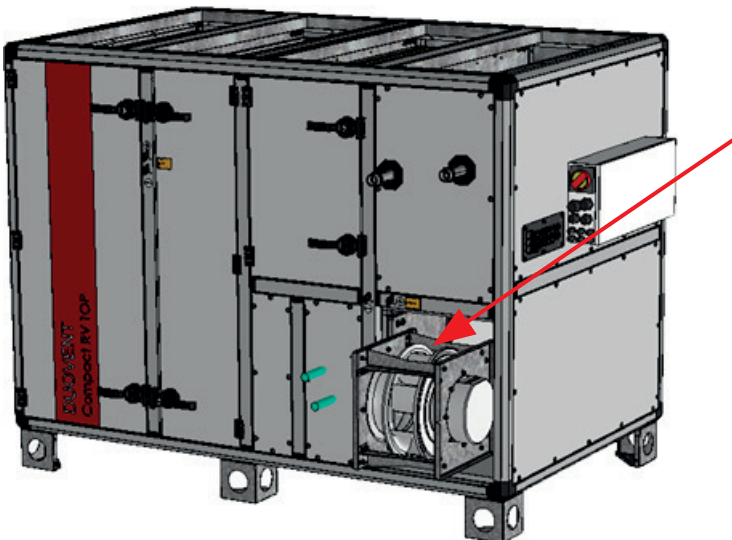

Removal of exhaust fan for DUOVENT® COMPACT RV 800-6000 TOP:

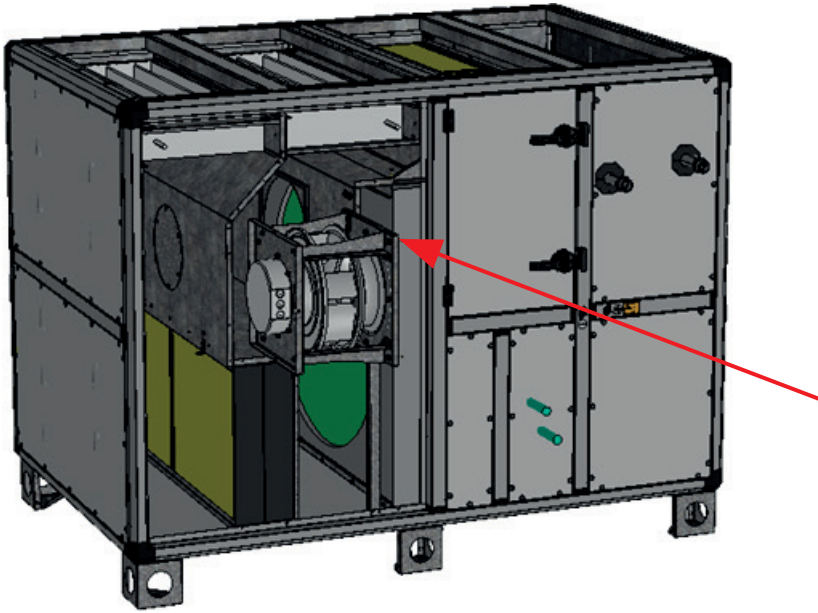

8.2.3 MAINTENANCE OF ROTARY REGENERATION HEAT EXCHANGER

Access to the rotary heat exchanger is via fixed panels which must be removed if necessary. To remove the panels, the caps of the plastic tubes must be removed. The panels are screwed in place with self-drilling square head screws. The heat recovery exchanger is protected by filters and can therefore only be contaminated very lightly. Nevertheless, it is recommended to carry out a visual check whenever the filters in the unit are changed. The visual inspection can be carried out after opening the door panels of the service side. It is forbidden to start or to operate the rotary heat exchanger with inspection door or panels open. Before starting maintenance, cleaning and servicing work on the rotary heat exchanger, the power supply must be switched off and measures must be taken to prevent the electric motor from being switched on during this work. To access the heat exchanger, open the front door by turning the locks. As part of the maintenance work, the tension of the drive belt, the rotor seals, the fouling of the rotor and the tension of the peripheral cladding of the split rotary heat exchanger must be checked. Cleaning is carried out with pressurised air, steam or pressurised water. Cleaning shall be carried out by a trained person. Serious damage to the rotor of the rotary heat exchanger is possible if the cleaning procedure is not carried out in a professional manner. In the case of split rotors, the manufacturer of the rotary heat exchanger recommends that after the first 80 hours of operation, a light tightening of the peripheral cladding (carried out evenly around the perimeter of the rotary heat exchanger - CAUTION OF OVALITY!!!) is carried out, including adjustment of the sealing elements.

8.2.4 PERIODIC INSPECTIONS

Perform periodic inspections at least once a year as part of a summer service inspection. It is optimal to carry out inspections twice a year, usually before and after the end of the winter season.

During the regular service inspection it is necessary in particular:

- Perform regular inspection and cleaning of the heat exchange surfaces of the exchangers
- Clean or replace filter inserts in air filters
- Check the condition of the damping inserts, especially their tightness, and replace them in time
- Perform inspections and checks of the function of electrical components (contactors contacts, tightening of terminals, condition of insulation...)
- Check the hinges and supports of the device
- Carry out regular inspections of those facilities for which the applicable laws, decrees, standards and rules so require
- Keep proper records and monitoring of the outcome of inspections and revisions and monitor the implementation of the measures taken
- Check the siphons for condensate drainage, especially their permeability and tightness, especially the tightness of the mounting on the unit and the tightness of the ball seating

8.2.5 SPARE PARTS

Warranty, post-warranty service and spare parts can be ordered from ELEKTRODESIGN ventilátory spol. s r.o. The manufacturer may entrust service to trained authorized service companies. Their list is at www.elektrodesign.cz. Contact details for authorized service are indicated on the yellow labels on each unit.



AUTHORISED SERVICE CENTER

ELEKTRODESIGN ventilátory s.r.o.

Tel.: +420 326 909 038

E-mail: servis@elektrodesign.cz

- repairs and service of ELEKTRODESIGN HVAC units
- repairs and service of HVAC units from other manufacturers
- sale of spare parts, replacing of filters

MO-FR 8:00-16:00



WARNING

Do not start and/or use the unit during constructions works (drilling, grinding etc.). There is a risk of unrepairable damage of the unit and distribution lines! The unit must be commissioned by an authorised person only!

If these instructions are violated, the manufacturer has no responsibility for any subsequent losses and the warranty for the HVAC unit becomes void!

9. DECOMMISSIONING AND RECYCLING



EU law and our responsibility to future generations oblige us to recycle used materials; do not forget to dispose of all unwanted packaging materials at the appropriate recycling points and dispose of obsolete equipment at the nearest waste disposal site. In case of any questions regarding our products, please contact any branch of ELEKTRODESIGN ventilátory spol. s r.o. To find your nearest dealer, visit our website www.elektrodesign.cz.

Annex number 1

INFORMATION ON COMMISSION REGULATION (EU) NO 1253/2014 (ANNEX 5, POINT 3)



INFORMATION REQUIREMENTS FOR VENTILATION UNITS FOR NON-RESIDENTIAL BUILDINGS UNDER ART. 4 PARAGRAPH 2.

DUOVENT® COMPACT series units contain parts with a proportion of plastic and electronic components intended for disassembly and subsequent recycling:

1. FLAP ACTUATORS
2. DTS PSA PRESSURE SENSOR
3. FAN IMPELLERS
4. PLASTIC PARTS OF FAN EC ELECTRIC MOTOR
5. PLASTIC PARTS OF THE CONTROL SYSTEM
 - A. TRANSFORMER
 - B. CONTROL BOARD
 - C. SECURING ELEMENTS
 - D. MAIN SWITCH
 - E. GLANDS
6. FILTERS WITH PLASTIC FRAME



1. FLAP ACTUATORS



- a. Open the unit door
- b. The device contains electrical and electronic components and must not be disposed of as household waste, local and currently valid legal conditions must be respected
- c. Disassembly of the actuator is performed by loosening the caliper and removing it from the flap shaft
- d. Tools used , 



2. DTS PSA PRESSURE SENSOR



- a. Open the unit door
- b. Pull to disconnect the rubber sampling hoses
- c. Remove the pressure gauge cover
- d. Disconnect the cable
- e. Remove the sensor
- f. Tools used , 

3. FAN IMPELLERS



- a. Open the unit door
- b. Disconnect the electric motor from the power supply and disconnect the ground cable of the fan frame
- c. Remove the impeller from the unit frame, remove the impeller from the unit
- d. Remove the electric motor from the impeller
- e. Tools used , , 

4. PARTS OF ELECTRIC MOTORS OF FANS



- a. Remove the electric motor cover
- b. Remove the plastic bushings of the electric motor
- c. The procedure for disassembling the electric motor is contained in Annex 1 to this manual

5. PLASTIC PARTS OF THE CONTROL SYSTEM

1. Voltage transformer
2. Control board
3. Securing elements
4. Main switch
5. Glands

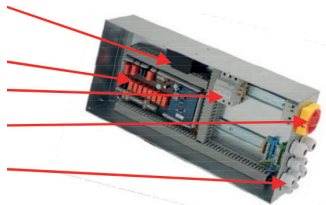

- a. Open the cabinet cover
- b. Disconnect cables
- c. Remove parts 1, 2, 3, 4, 5
- d. Tools used 

6. FILTERS WITH PLASTIC FRAME

- a. Open the unit door
- b. Slide out the filters
- c. Tools used 





DISASSEMBLE INSTRUCTIONS

www.elektrodesign.cz

Disassemble instructions of EC blue motors with external rotor sizes B (090), D (116) and G (152).

1. GENERAL

This manual is used for disassembly and ecologically meaningful disposal of ECblue engine components with external rotor according to Regulation (EU) No. 1253/2014. It applies to motor sizes “B” (090), “D” (116) and “G” (152).

The design size of the motor is identified by the type designation (see rating plate).

Examples for type identification by means of the motor design size B = 90

Motor type	Type of axial fan	Type of radial fan
MK090 - _ I	F _ _ _ _ - I . B _	RH _ _ _ - I . B _
		GR _ _ _ - I . B _
		ER _ _ _ - I . B _

2. SAFETY INSTRUCTIONS



CAUTION!

- The product installation instructions must be followed! Particularly all safety regulations must be adhered to!
- Risk of injury due to high magnetic attraction of the rotor and stator!

3. FAN DISASSEMBLY



RISK OF ELECTRIC SHOCK!

- 5 rules of the electric safety must be followed!
- During automatic motor operation, eg by air flow or deceleration after switching off, dangerous voltages higher than 50 V can be generated at the internal motor connections during operation of the generator.
- Due to the use of a capacitor, there is a risk of death even after switching off if it comes into direct contact with live parts or live parts.
- The control box can be removed or open only with the mains supply disconnected and after three minutes.

Procedure

1. Disconnect the mains voltage and secure against being switched on again.
2. Clean the fan of external dirt before disassembly.
3. Depending on the type of fan, external components such as the wall ring (2) and the support grille (1) must be removed and checked for reusability.



4. Remove the housing from the controller cover at the earliest after a waiting time of 3 minutes.
5. Check the no-power condition.
6. Disconnect or remove all electrical wiring.

4. DISASSEMBLY TOOLS

The disassembly requires following tools:

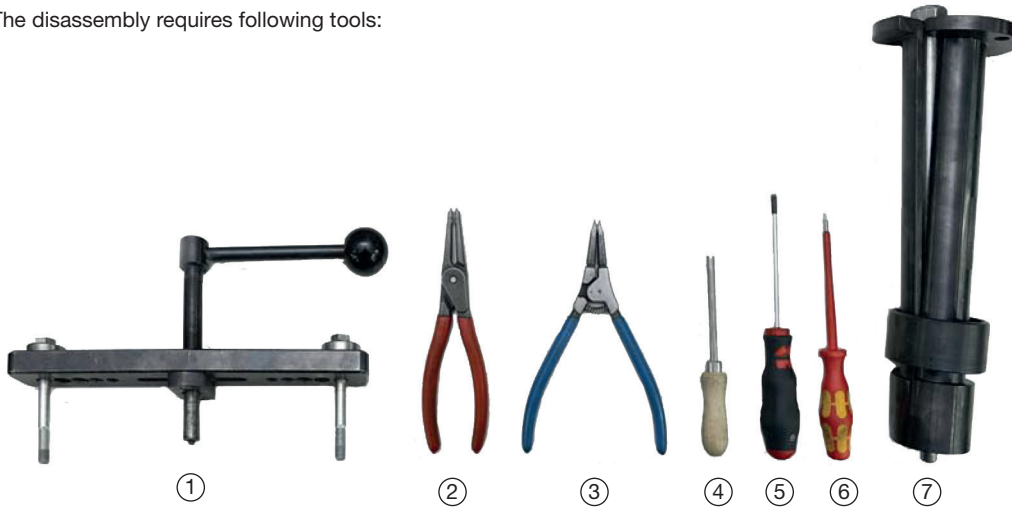

1. Beam expander
2. Pliers for the outer circlip
3. Pliers for inner circlip
4. Opening tool for motor sizes D (116) and G (152)
5. For motor sizes B (090) screwdriver TX20 (TR TX20 for Allen key), for motor sizes D (116) and G (152) screwdriver TX25
6. Slotted screwdriver (eg 0.6) for motor sizes D (116) and G (152)
7. Shrink sleeve including circular material for removing the ball bearing on the stator side

Special tools available from ZIEHL-ABEGG

Motor design size	Opening tool		Beam expander		Extracting sleeve	
	Drawing number	Product numbers	Drawing number	Product numbers	Drawing number	Product numbers
B (090)	–	–	6003-201	00280698	6003-212	00703644
D (116)	6003-019	00161068	6003-202	00280682	6003-209	00295437
G (152)	6003-019	00161068	6003-202	00280682	6003-211	00296476

5. DISASSEMBLY PROCEDURE

5.1 OPEN THE ENGINE

Remove the housing from the controller cover

- For motor size B (090)
- Loosen the 2 x Allen screw from the connection compartment cover with a "5" TX20 screwdriver.
- Loosen the TR safety Allen screw 4 times with a screwdriver „5“ TX20 from the controller cover.
- For motor size D (116), loosen the 5 screws (Kombi Torx T20) with a screwdriver „5“.
- For motor size G (152), loosen the 6 screws (Kombi Torx T20) with a screwdriver „5“.

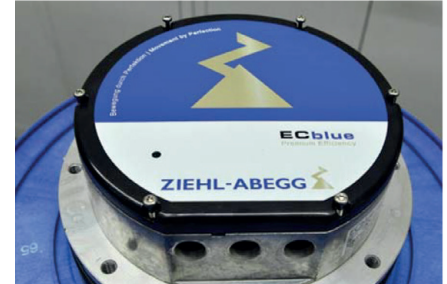
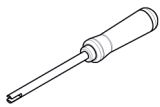

Illustration of motor size G (152)

Engine sizes D (116) and G (152)

- If necessary, remove the present add-on module from the connector.
- Loosen the locking pin with the opening or unlocking tool „4“.



INFORMATION
Earlier versions are made with a plastic screw with a Torx T10 Allen screw, which must be loosened here.



- Push the retaining clips out with a screwdriver „6“ and remove the black inner cover.



5.2 DISASSEMBLE THE ENGINE AND PULL OUT THE BALL BEARINGS

- Remove the inner circlip with pliers „3“ and discard.



CAUTION!
Do not reuse the circlip due to the risk of overturning.

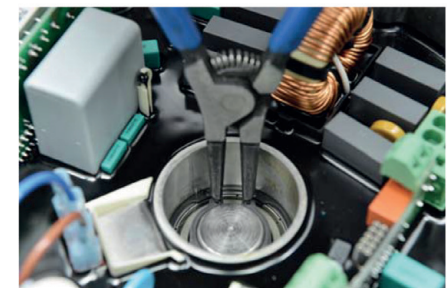

- Remove and dispose of the plastic plate.



INFORMATION
The plastic plate is not in the design with hybrid bearings and steel shaft without plastic coating.



CAUTION!!
Do not reuse the plastic board.



DUOVENT® COMPACT RV TOP

- Remove the outer circlip with pliers „2“ and discard.



CAUTION!
Do not reuse the circlip due to the risk of overturning.

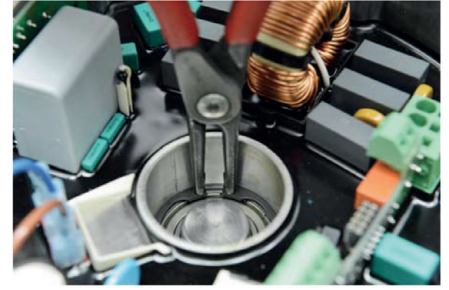

- Place the puller „1“ on the stator and fasten it to the stator flange.

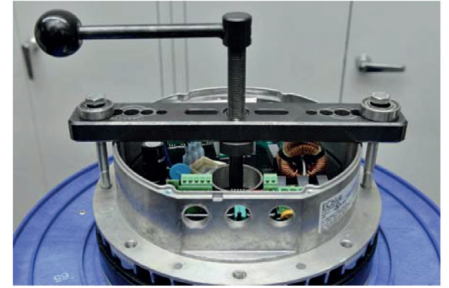

- Pull the stator „A“ away from the rotor using the spreader „1“ by pressing the threaded spindle on the front face „Z“.
- Pull the stator „A“ out of the magnetic field of the rotor „B“ using an expander.
- Remove the expander from the stator.

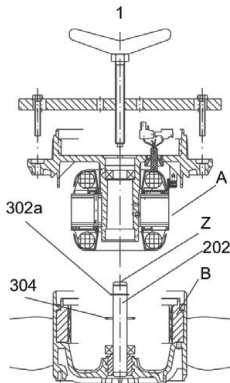

CAUTION!

- Under no circumstances should you attempt to separate the stator from the motor manually without using an expander.
- Strong attraction between the stator A and rotor B is due to high electromagnetic forces – risk of injury!

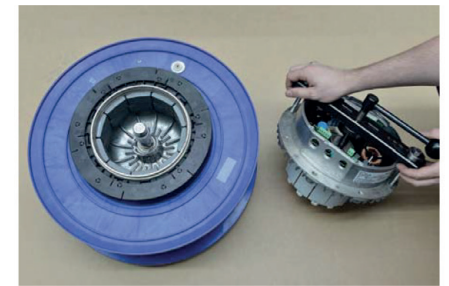

- Remove and dispose of the plastic plate.



INFORMATION
The recent variants do not feature the plastic board and circlip!



CAUTION!
Do not reuse the circlip due to the risk of overturning.



- Remove and discard the lower circlip „302a“ using pliers „3“.



INFORMATION
The recent variants do not feature the plastic board and circlip!



CAUTION!
Do not reuse the circlip due to the risk of overturning.



- Remove the ball bearing on the stator side with a suitable round material.

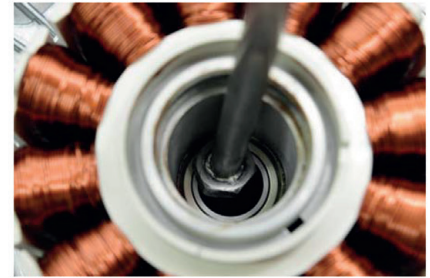

- Use the shrink sleeve „7“ to remove the ball bearing on the rotor side.

If no suitable press is present, the ball bearing can also be moved using an expander and a shaft.



- Remove the plastic plate from the shaft and discard.



INFORMATION

- Only with rotor made of die-cast aluminum.
- For steel rotor versions, remove the plastic cooling wheel located on the bottom of the rotor and dispose of it.



Rotor made of die-cast aluminum with plastic plate (not shown) on the ring.

Remove the plastic cooling rings from the rotor flange with a suitable lifting tool (eg with a screwdriver “6”) and dispose of them.



INFORMATION

- For motor size G with steel rotor, loosen screw M5 instead with a screwdriver “5” TX25, then remove the cooling ring.



Steel rotor with plastic cooling wheel.



CAUTION!
Disassembled components shall not be reused!

6. DISPOSAL / RECYCLING

Disposal must be carried out professionally, ecologically and in accordance with the legal provisions in force in the respective country.

- Sort materials by type and ecologically
- If necessary, entrust the disposal to a specialist company